

REVERSE OSMOSIS SYSTEM

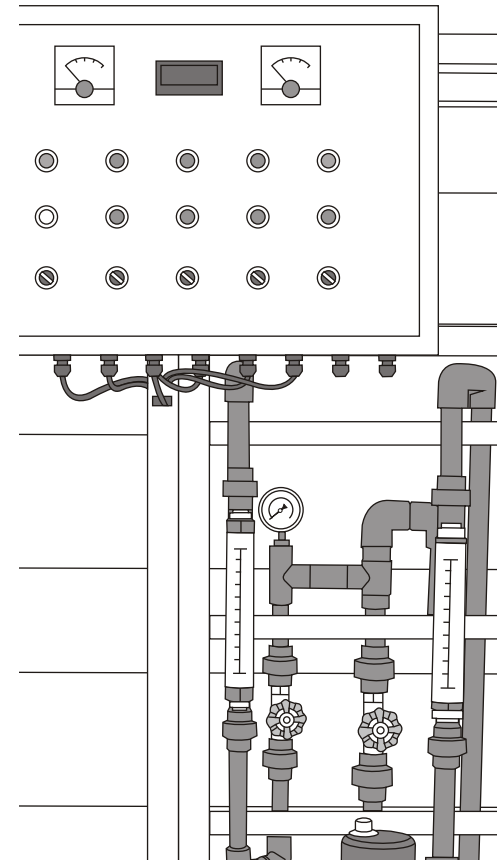

**RO36000-
RO48000
Industrial
RO System**

- 01 Feed water quality requirement
- 01 System specifications
- 02 Part list
- 07 Installation
- 08 Operation process & maintenance
- 10 Trouble shooting
- 13 Electric protective switch

Thank you very much for selecting Pure-Pro Water Corp.
In order to bring the best use of your system, please read the user's manual carefully before installation and follow the regulations.

■ Feed Water Quality Requirement

Feed water pressure	2KG / cm ² ~ 4KG / cm ²
Hardness	<50 PPM (AT CaCO ₃)
Cl	< 0.1 PPM
Turbidity	< 1 NTU
Feed Water TDS	< 1500 PPM

PS: Other than water quality described above, Please contact a nearest technician for more info.

■ System specifications

Models	36000GPD	48000GPD
Dimension (cm)	(L)90 x (W)316 x (H)150	(L)90 x (W)316 x (H)150
N.W	≐ 520 KG	≐ 590 KG
Voltage	Available in 380V, 410V, 440V	Available in 380V, 410V, 440V
Hertz	Available in 50 Hz, 60Hz	Available in 50 Hz, 60Hz
Current	11.7A	11.7A
Booster pump	5.5KW (7.5HP)	7.5KW (10HP)
In / Out diameter	IN 1 1/2" / OUT 1"	IN 1 1/2" / OUT 1"
RO membrane housing	SUS316 8080 x 3	SUS316 8080 x 4
RO membrane	TFC-BW-8040 x 6	TFC-BW-8040 x 8
Pre-filters	30"-PP x 7	30"-PP x 7
Pressure gauges	Inlet / Operation	Inlet / Operation
Water quality indicator	T.D.S.	T.D.S.
Water flow indicator	Flow meter x 3	Flow meter x 3
Controller	Digital computer controller box	Digital computer controller box

■ Note

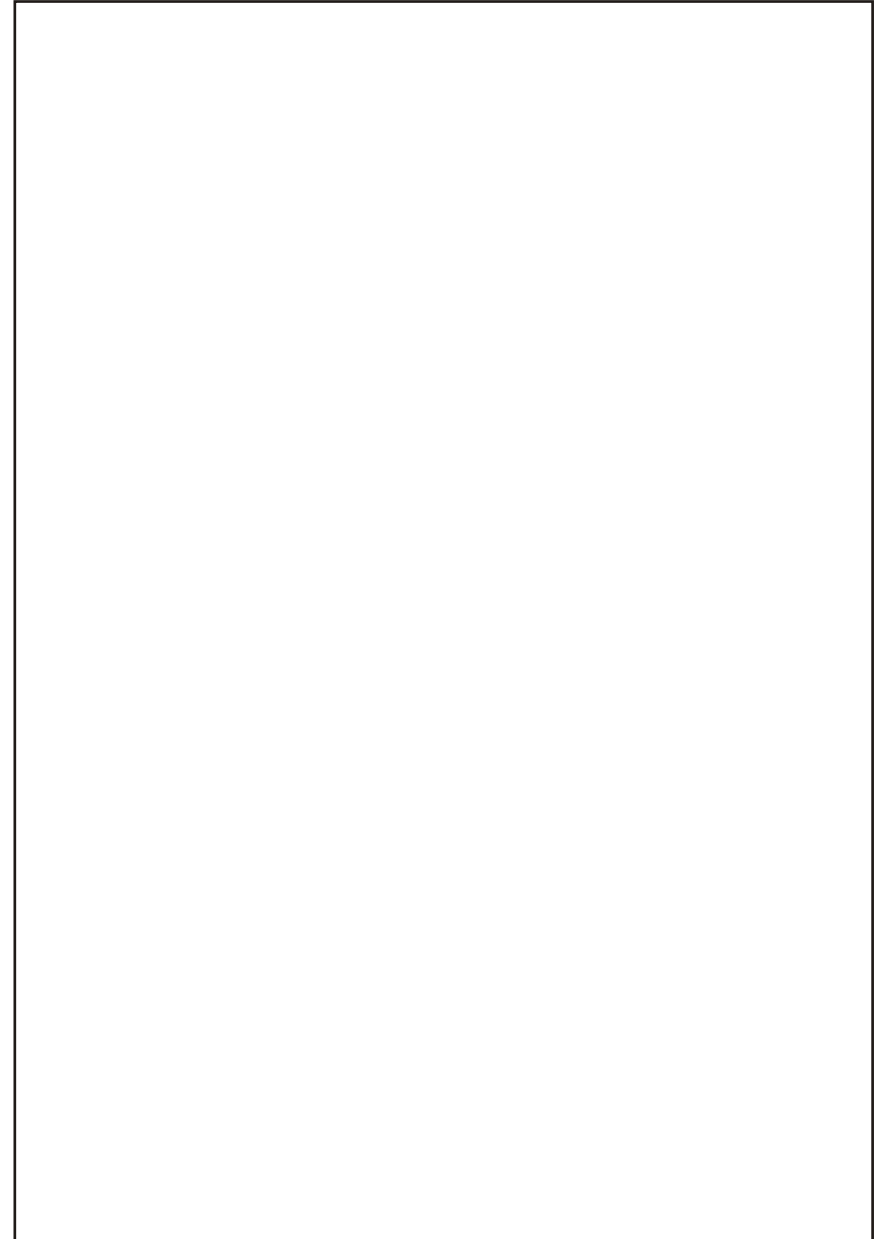

■ Electric protective switch

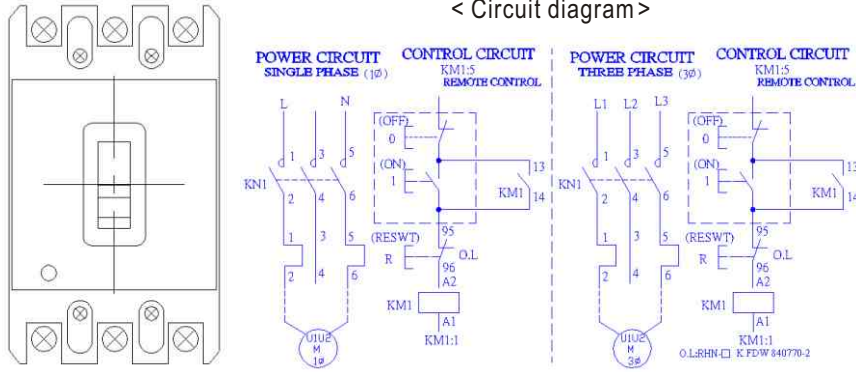

Low pressure switch

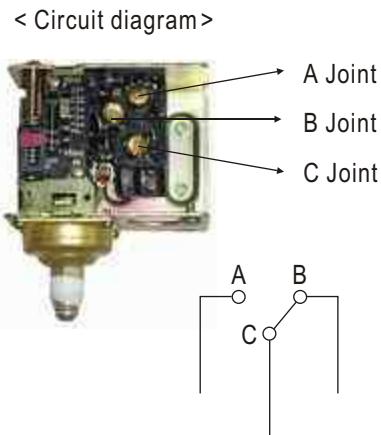
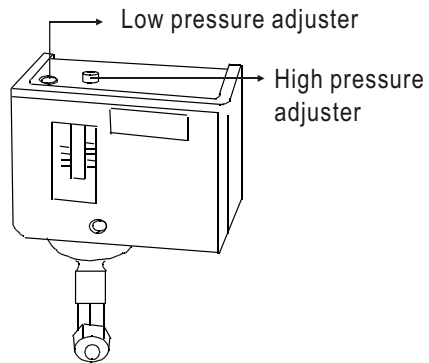

1. Low pressure adjuster:
To lower pressure, turn anticlockwise and vice versa.
2. High pressure adjuster:
To rise pressure, turn anticlockwise and vice versa.

- Joint points:
1. No joint on A
 2. B and C joints are connected with green wire to Control box

■ Part List



Item	Parts	Specification
01	Voltmeter	600V (max.)
02	Pure water TDSmeter	W32D
03	Electric current meter	30A (max.)
04	Feed water Low-pressure-switch alarm	24V-YL
05	Feed water pump overload warning	24V-RL
06	High pressure pump overload warning	24V-RL
07	Electric valve off indicator	24V-RL
08	Flush indicator	24V-YL
09	Power	220V-WL
10	Feed water functioning indicator	24V-GL
11	High pressure pump functioning indicator	24V-GL
12	Electric valve on indicator	24V-GL
13	Water full indicator	24V-GL
14	Power control switch	OFF / ON
15	Feed water Pumpswitch	MANUAL / OFF / AUTO
16	High pressure pump switch	MANUAL / OFF / AUTO
17	Electric valve switches	MANUAL / AUTO
18	Flush switch	OFF / ON



Industrial RO System

Problems	Possible causes	Solution
RO system is not functioning	1. Wrong setting for computer controller.	1. Check the setting.
	2. The pressure of feed water isn't high enough. (should be higher than 1.5kg / cm ²)	2. Check water-in pressure and if pre-filter clogged.
	3. The location difference between RO system and feed water tank.	3. Change the control method of RO system and adjust low pressure switch.
	4. The power for RO system is abnormal.	4. Check power supply and also adjust voltage. Tolerance to be within the ± 5% is considered as normal.
RO system can't work after flushing	1. Control box in condition of high water level.	1. Check pure water tank and circuit of high water level.
	2. Control box in condition of low water level.	2. Check feed water and pre-filters and pump.
	3. Control box is malfunctioned.	3. Change computer box.
Insufficient water output of RO membrane	1. Flush solenoid valve is malfunctioned.	1. Change flush solenoid.
	2. Restrictive valve is not fully open.	2. Adjust the restrictive valve.
	3. Pressure needle valve is malfunctioned.	3. Adjust pressure needle valve and check if needle valve is normal.
	4. Insufficient inlet water pressure.	4. Pump head is worn out thus cause insufficient pressure.

Industrial RO System

Problems	Possible causes	Solution
Membrane clogged	1. There isn't sufficient softened water supplied to the RO system.	1. Check the water softening process and also calculate if softening quantity can supply the RO system to purify.
	2. Drain valve or tubing clogged.	2. Check drain valve and tubing.
	3. The rate of drain and pure water shows abnormal.	3. Adjust the rate to/or above 1:1.
	4. The TDS of feed water (or the recovery TDS) is too high.	4. Check feed water source and also decrease the recovering rate. The consistence of recovery must be less than TDS 1500 PPM
	5. Colloid suspension is too much.	5. Install UF or 0.45u minus filter on pre-filters.
	6. Feed water quality is too poor.	6. Improve the feed water quality or increase pre-filters.
	7. Contained too much Iron.	7. Expose to air or add medicament for re-filtration.

Industrial RO System

Item	Parts	Specification
19	Feed water connection	1 1/2"
20	Feed water check valve	SCH-80-1 1/2"
21	Feed water deliver valve	SCH-80-1 1/2"
22	Sediment filtration tank valve	SUS3/4"
23	Sediment filtration tank	TK7-20
24	Feed water gauge	10KG
25	Feed water pressure switch	HS-506
26	Feed water Electric valve	OM1-1 1/2"
27	Main pump	CR10-12
28	Pump water outlet check valve	SUS 1 1/2"
29	Pump water restrictor	SUS 1 1/2"
30	*Anti-scalant valve	SCH-80-1"
31	1st. RO membrane housing pressure gauge	25KG
32	1st. RO membrane housing	SUS#316-8080
33	2nd. RO membrane housing pressure gauge	25KG
34	2nd. RO membrane housing	SUS#316-8080
35	3rd. RO membrane housing pressure gauge	25KG
36	3rd. RO membrane housing	SUS#316-8080
37	Operation pressure gauge	25KG
38	Operation pressure adjustable valve	SUS1"
39	Recycled water flow meter valve	SUS3/4"
40	Recycled water flow meter	10GPD
41	Drainage meter	30GPD
42	Flush electronic solenoid valve	MD-25
43	Drainage outlet	SCH-80-1"
44	1st. RO membrane housing pure water outlet	SCH-80-1"
45	2nd. RO membrane housing pure water outlet	SCH-80-1"
46	3rd. RO membrane housing pure water outlet	SCH-80-1"
47	*Anti-scalant flush valve (open-end)	SCH-80-1"
48	*Anti-scalant flush valve (close-end)	SCH-80-1"
49	*Anti-scalant water outlet valve (close-end)	SCH-80-1"
50	Pure water outlet	SCH-80-1"
51	Pure water flow meter	30GPD
52	Pure water TDS meter	W32D

Industrial RO System

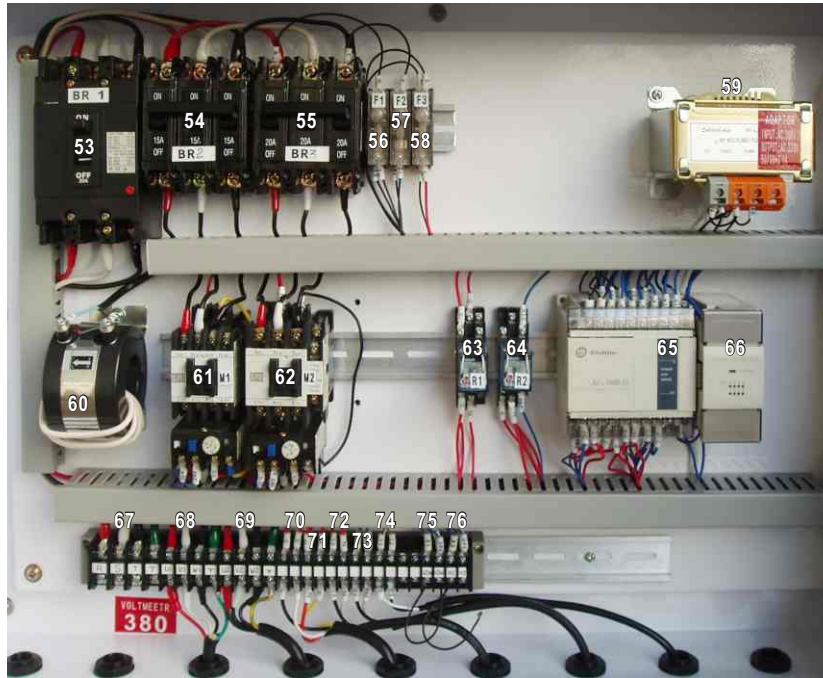

■ Trouble shooting

Problems	Possible causes	Solution
Pump doesn't work	1. Wrong power in.	1. Check power phases.
	2. Electrical solenoid switch is malfunctioned.	2. Check the coil and joint points (use a multimeter RX1 to see if it's connected.)
	3. Electrical solenoid switch is overload, protective switch shuts down.	3. Measure the operation current with clamp meter, and also set the measurement to be 1.25% more. (Press the stick back)
	4. Control box is on the condition of lower water pressure.	4. Check the pressure difference between water-in and pre-filter, also if the joint point to low pressure switch is connected. (use a multimeter RX1)
	5. Tank shut-off switch is malfunctioned / The joint point for post carbon and sand filter isn't connected.	5. Check the joint between with multi-meter RX1, and test if AB point is correct.
	6. Control box is malfunctioned.	6. Check if there is electric current output to electrical solenoid switch from the brown wiring of computer box. Also check if the power supply is normal.
	7. Axle center of pump is clogged with rust	7. Check if noise appears when pump works. If so please change the pump.
	8. Pump head is stuck	8. Please remove pump head. Check if the manual pump head can work. If not please change the pump head.

Shut off Process:

- A. Switch the high pressure pump to OFF.
- B. Switch feed water pump to OFF.
- C. Switch power control to OFF.
- D. Switch power supply fuse to OFF.
- E. Switch water outlet check valve to OFF.

■ Maintenance**Maintenance:**

1. Pre-treatment Filter: According to the water quality, service life can last for 1~3 months.
2. Check the actual fluid of permeate for concentrate water. Make a record. Once the permeate water production is down to 10~15% of the normal production for, an acid washing for the RO membranes is required.
3. Check inlet water and operation pressure.

Item	Parts	Specification
53	Power supply fuse switch	3P 30A
54	Feed water pump fuse switch	3P 15A
55	High pressure pump fuse	3P20A
56	Main electric circuit fuse R	2A
57	Main electric circuit fuse T	2A
58	Electric circuit control fuse	2A
59	Transformer	380V~220V 2A
60	Electric current signal converter	5:1
61	Feed water pump	MSP11-1HP
62	High pressure pump solenoid valve	MSP16-5.5HP
63	Electric control valve signal converter	R1(MY2NJ)
64	Electric recycling valve signal converter	R2(MY4NJ)
65	Programmer controller	AX1N-24MJ
66	Backup programmer controller	8EY
67	Main power input	R.S.T.G
68	Feed water pump output	U1.V1.W1.
69	High pressure pump output	U2.V2.W2
70	Electronic solenoid valve connecting points	5(on), 6(off), N(COM)
71	Waster water recycling connecting points	4, N
72	Flush solenoid valve output	Y4, N
73	Internal pressure protector	X2, 24V
74	TDS detecting pints	11, 12
75	Low-pressure switch connecting points	X1, 24V
76	Tank shut-off switch connecting points	X3, 24V

■ Installation

1. Connect PVE tubing to 1 1/4" water-in and ball valve pipe.
2. Connect 1" tubing to "drainage" as indicated.
3. Connect 1" tubing to "pure water" as indicated. (or to water storage tank, if)
4. Connect earth link wire (green) from the control box to the floating ball switch on the tank in order to control full water leverage.
5. Connect power supply. (Note: voltage)

NOTE:

1. Please confirm the power supply applied to the system.
2. Please confirm the connection of pure and drain water tubing to be correct.
3. Please confirm the inner diameter of main power wire no less than 3.5mm²
4. Wires connected to full water switch and floating switch shall not be used for other purposes.
5. When with connection to water softener, please set up the reverse flush switch function to prevent the main RO system from sucking in the resin and salt water. (the main RO system should stop operating when reverse flush starts)
6. Please clean pre-filters every week in order to receive sufficient water-in supply.

■ Operation process & Maintenance

Attention Before Operation:

- A. Feed water pressure exceeds 2.0Kg/cm²
- B. Supply the same electrical current in accord with the voltage of the main system. Supplied electrical current is better within $\pm 5\%$ in compare to the main system voltage.
- C. Connection for pure / drainage is completed.
- D. Valves are switched to the correction direction. (feed water check valve: SCH-80-1 1/2", anti-scalant valve: SCH-80-1", anti-scalant flush valve (close-end) SCH-80-1" should be OFF; feed water deliver valve SCH-80-1 1/2", pump water restrictor: SUS 1 1/2", operation pressure adjustable valve: SUS1", anti-scalant flush valve (open-end) SCH-80-1", should be ON).
- E. Switches for the panel controller turned to the correct direction.

Operating Process: (Pre-operating have been checked)

- A. Switch on power supply.
- B. Swift the switch for feed water pump to AUTO; check the feed water pressure (24) to ensure the pressure is between 2~4Kg.
- C. Swift the switch for High pressure pump to AUTO.
- D. Swift Electric valve switches to AUTO.
- E. Swift Flush switch to OFF.
- F. RO system begins auto checking for 5 seconds. (low-pressure switch, tank shut off switch, feed water pump, feed water solenoid valve)
- G. Check if the electric current is working within the indicated pump range.
- H. Adjust the ratio and pressure of permeate water and concentrate water:
 - a. First adjust the operation pressure adjustable valve SUS1 and recycled water flow meter valve SUS3/4", to decide the proportion among pure water, drainage and recycled water. (25GPM : 20GPM : 5GOM). the worst the water quality is, the bigger the proportion to be made.
 - b. Adjust restrictor flow on high pressure pump to the same amount of pure water production.
- I. During production of water, system starts auto-flush every hour.
- J. When water storage is tank, system shuts off automatically.
Water storage tank is an optional item.