

Memo

Type of product			
Date of purchase			
Name		Tel	
Address			



REVERSE OSMOSIS SYSTEM

RS-106R

USER'S MANUAL

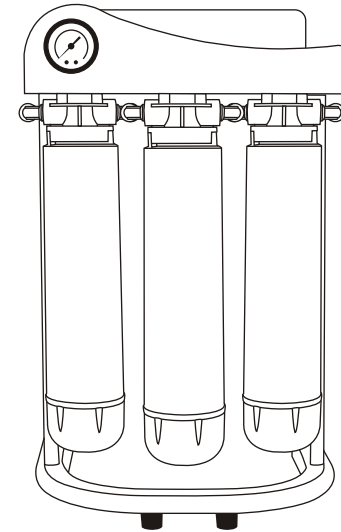

- 01 Introduction of RS-106R
- 02 What is reverse osmosis
- 03 Components & Selected filters
- 04 Cartridge filters
- 05 The parts of RS-106R
- 06 Tubing connection diagram
- 07 Installation diagram
- 08 Change filters
- 09 Change membrane
- 10 Operation regulation
- 12 The functions of Infra-Red filter
- 13 FAQ
- 14 Maintenance checking list
- 15 Memo

Thank you very much for selecting Pure-Pro Water Corp.
In order to bring the best use of your system, please read the user's manual carefully before installation and follow the regulations.

Introduction of RS-106R

RS-106R Quick-change cartridges RO system

PurePro® ROYAL RO system uses the most advanced water treatment technology: "Reverse Osmosis". Reverse Osmosis (RO) is recognized as one of the best available technologies for producing best quality drinking water. It's also the same method used by many bottled water companies to make safe and great tasting water. No other home water treatment system can offer you as much protection and reliability.

PurePro® ROYAL RO system uses 100GPD membrane which is powerful, fast and excellent efficiency. 100GPD membrane increase the daily production capacity and the speed of RO water production. This allows for better assurance that there is adequate water available when desired, even during heavy use times of the day. PurePro® ROYAL RO with its supreme quality ensures a great water flow rate with absolutely the least wasting of water.

The newly designed ROYAL RO system is user friendly with design simplicity in mind. It requires no tools for filter changes. Use twist and quick-change cartridge design makes filter changes fast, clean and easy. This space saving allows maximum use of your under counter space.

Specifications

- Production: 100 GPD / 378 LPD
- Water storage tank: 3.2 gallons / 12.2 liters
- Operation pressure: 50 - 100 psi
- Dimensions: (cm) 27.5 (L) x 44.5 (H) x 26.5 (W)
- Weight: 9 kg - system
4 kg - tank

Maintenance checking list

Filters	1st stage	2nd stage	3rd stage	4th stage	5th stage	6th stage
Date						

FAQ

Q: What is the guarantee on the PurePro system ?

The PurePro system (excluding filters) is guaranteed for 1 year for material and workmanship. All defective parts will be replaced free within the first year under natural breakdown. The membrane has one year pro-rated guarantee.

Q: What factors affect the quantity and the quality of the water production?

There are four major variables to consider:

1. **Pressure**-The greater the water pressure, the better water quantity and quality it produced. Water pressure of 60 PSI is ideal.
2. **Temperature**-76°F is the ideal water temperature for R.O. 40°F water will cause the production of R.O. water to fall to half of that at 76°F. The maximum water temperature recommended is 85°F.
3. **Total Dissolved Solids (TDS)**-The higher the amount of dissolved contaminants in the water, the lower the quantity of water produced. A high level of TOTAL DISSOLVED SOLIDS can be overcome with additional water pressure.
4. **Membrane**-Different membranes have different characteristics. Some produce more water than others; some have better contaminant rejection capabilities; some have greater resistance to chemical abrasion for longer life. PurePro system includes TW30-1812-100 The Thin Film Composite (TFC) membranes combine the best of these characteristics and are considered the finest membrane in the world.

Q: Can the PurePro system be connected to an extra faucet?

It only takes a 1/4" tee and tubing to run the water to a refrigerator or a extra faucet. Some families run PurePro system to all of their bathrooms.

Q: What does the PurePro series drinking water taste like?

The taste of the PurePro water depends on the amount of contaminants in the tap water originally. If 95% of dissolved minerals and chemicals are removed, the R.O. water may taste like distilled water (no minerals), bottled water (low mineral), or natural spring water (moderate mineral content).

What is reverse osmosis

Reverse osmosis was originally designed to make sea water drinkable for the navy. It is ideal for anyone on a low sodium diet. An R.O. membrane has a pore size much smaller than bacteria virus, or the cryptosporidium parasite. When functioning properly it will remove all microorganisms from tap water and produce sterile water. Reverse osmosis is the reversal of the natural flow of osmosis. In a water purification system, the goal is not to dilute the salt solution, but to separate the pure water from the salt and other contaminants. When the natural osmotic flow is reversed, water from the salt solution is forced to pass through the membrane in the opposite direction by application of pressure-thus the term REVERSE OSMOSIS. Through this process, we are able to produce pure water by screening out the salts and other contaminants.

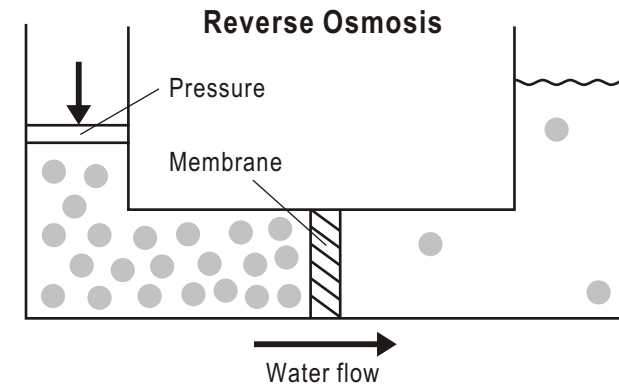

Components & Selected filters

Components

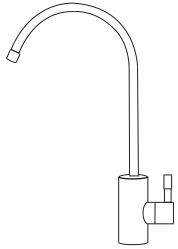

European ceramic faucet

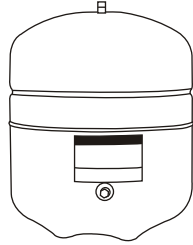

Water storage tank

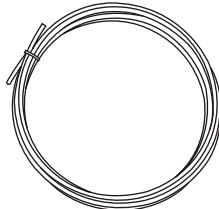

Tubing

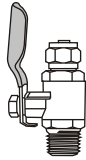

Deliver-valve

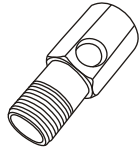

Water supply connector

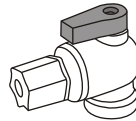

Tankball shut-off valve

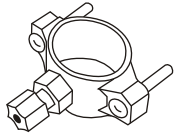

Drain saddle

Selected filters



Mineral cartridge filter

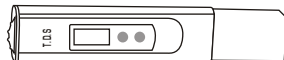

TDS meter



Infra-red cartridge filter



UV water sterilizer

The functions of Infra-Red filter

Far Infrared rays (FIR) are part of the sunlight spectrum, which is invisible to the naked eye. The wavelength of the far infrared rays ranges from 4 microns to 1000 microns. The recent studies in biotechnology field revealed that the far-infrared rays played an important role for formation and growth of all living organisms. For this reason, these specific far-infrared rays are called "biogenetic rays". Water and proteins are the integral parts of all living organisms on Earth. Water molecules are always oscillating. Water makes up 70% of mass of the human body. FIR is able to activate, revitalize, reactivate, develop and strengthen various organs in our bodies when it is absorbed.

In the various organs of human body, the circulatory system plays an important role, especially in micro-circulatory system. When there are problems with micro-circulatory system, various ailments will occur. FIR vibrating at a frequency similar to that of human body is able to penetrate the body activates cells and reactivates as well as strengthens the micro-circulatory systems. It regulates the blood flow and blood in blood vessels, which have been blocked due to blood clots and at the same time reactivate the vital energy in the body.

Elevation of the immunity of our bodies against diseases is another benefit of FIR waves. This is part of the effects of the improvement in micro-circulatory system and metabolism of the body. It helps slow down the aging process, increase resistance against diseases and increases longevity.

The effect of Far-infra-red rays to our human body is as follows:

- Activating water molecules in our body
- Improving oxygen level and nervous in our body
- Warming and eliminating fats, chemicals, toxins, and other waste from our blood and thus smoothing the flow of blood
- Reducing the acidic level in our body
- Preventing bacteria from growing
- Relieving pain
- Softening of hard water
- Eliminating bad odor in water
- Purifying air
- Strengthening and improving health
- Speeding up repair of body cells
- Balancing acid level in human bodies
- Normalizing blood cholesterol
- Preventing mould
- Enhancing and maintain freshness
- Helping plants grow better





Operation regulation

- A. With everything connected, turn on the water check for leaks.
- B. Make sure the storage tank shut-off valve is "OFF". Open the sink top faucet.
- C. Within a few minutes (up to 15) the water will start to run from the faucet slowly.
- D. Let the water run for at least 30 minutes. This flushes the carbon filters on firsttime use.
- E. After initial flushing, open the shut-off valve on the tank and close the sink top faucet.
- F. Tank will now full of water (usually 2 to 3 hours) after the tank has filled. Open the sink top faucet and drain all water until the storage tank is empty and there is only a small flow from the sink top faucet.*** DO NOT USE FIRST TANK OF WATER.***
- G. Close the sink top faucet. The system is now ready for use.
- H. Change filters regularly every 6 to 12 months and have the membrane checked annually.

Caution

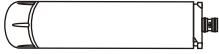
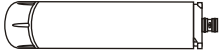
1. Do not use hot water (over 45°C)!
2. Do not freeze the machine!
3. Switch off electricity and water source if away for more than 5 days, and drain out pure water.

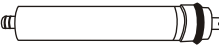
Cartridge filters

Cartridge Filters	Filter Description	Service Life
Stage 1 5 Micron Sediment Filter 	RS300ST With only five micron rating. It is effective in removing dirt, rust and sand particles.	6 Months
Stage 2 GAC Carbon Filter 	RS300ND It takes out 99% of the chlorine and organic chemicals. It provides enhanced reduction of taste, odor, and color.	6 Months
Stage 3 CTO Carbon Filter 	RS300RD It takes out 99% of the chlorine and organic chemicals. It provides enhanced reduction of taste, odor, and color.	6 Months
Stage 4 TFC Membrane 	A thin film composite (TFC) high quality membrane that processes 100 gallons per day. It remove the following hard water contaminants that may be present in your water: lead, cooper, barium, chromium, mercury, sodium, cadmium, fluoride, nitrite, nitrate, and selenium.	2 Years
Stage 5 Post Carbon Filter 	NSF approved. This post carbon filter is designed to improve taste. It removes any residual impurities and odors from the tank and provides a finer conditioning of pure water.	1 Year
Stage 6 Infra-Red Filter 	This Infra-Red filter can activate water molecules in our body and improve oxygen level in our body. Warm and eliminate fats, chemicals and toxins from our blood and thus smoothen the flow of blood.	1 Year

The parts of RS-106R

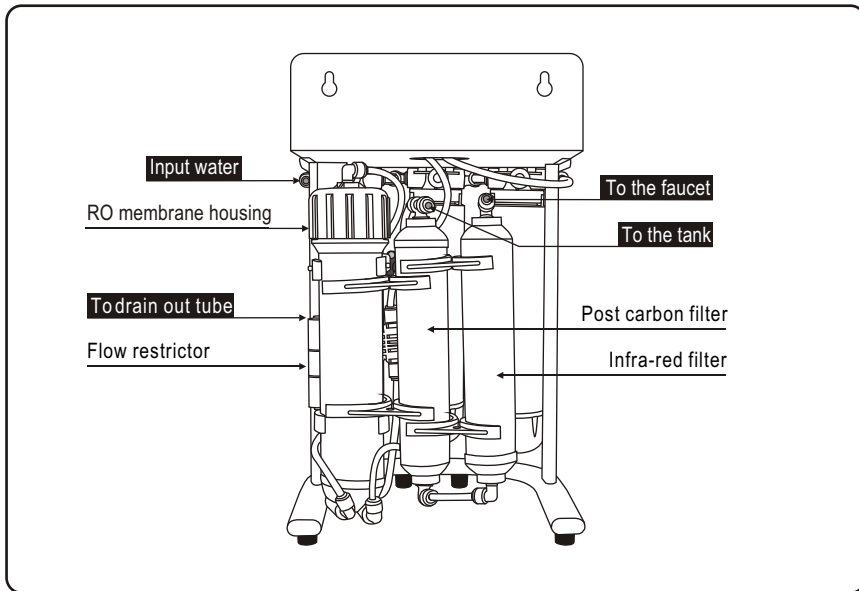
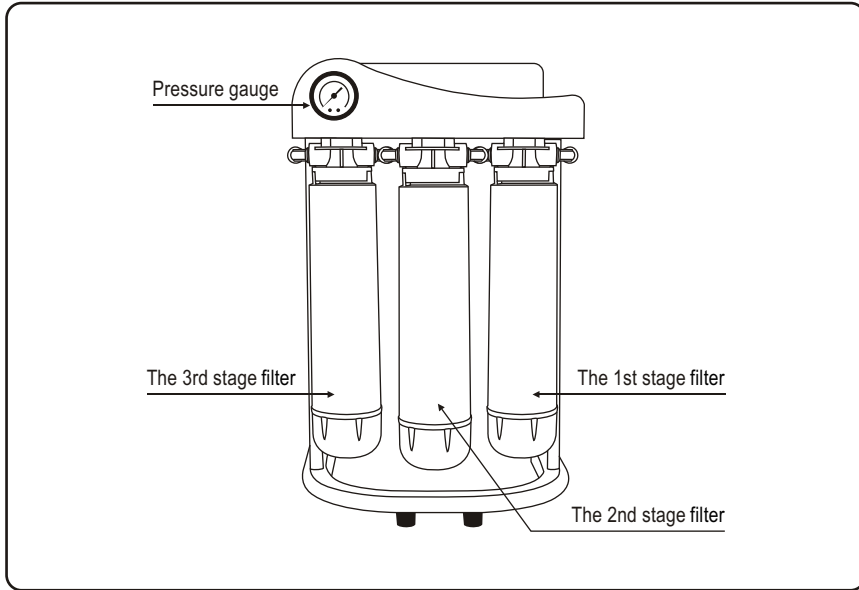

ROYAL Reverse Osmosis Drinking Water Systems

Operation regulation

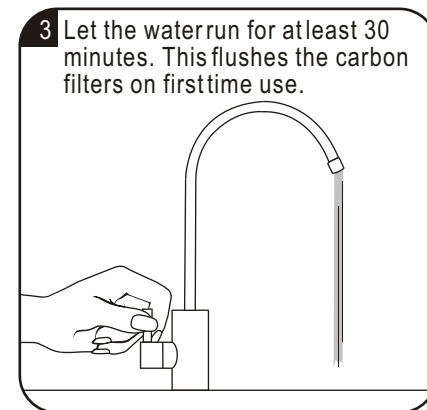
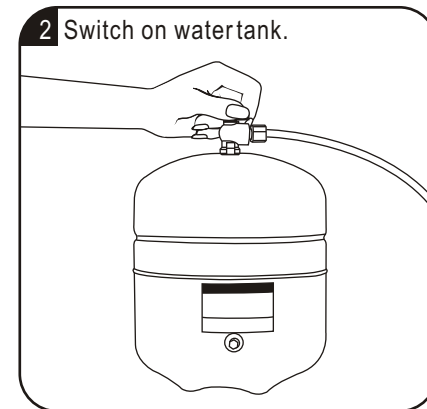
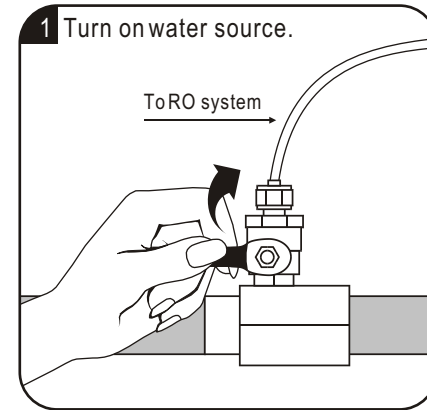

ROYAL Reverse Osmosis Drinking Water Systems

Change membrane

1 Turn off water source.

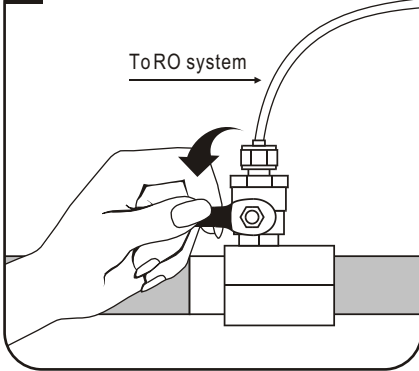

2 Switch off water tank.

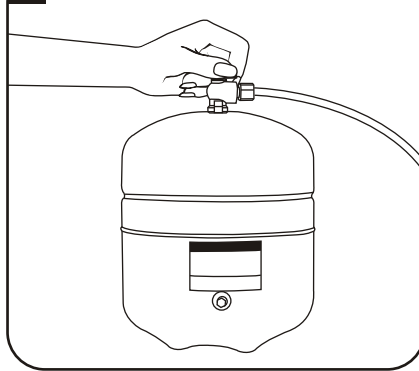

3 Remove the tube.

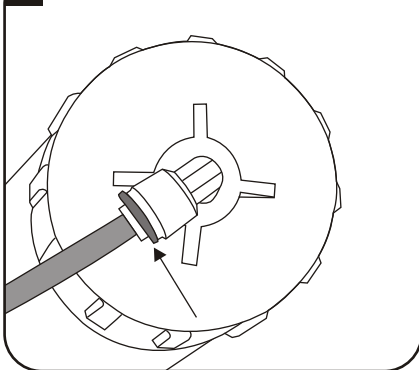

4 Remove the membrane housing cap anticlockwise.

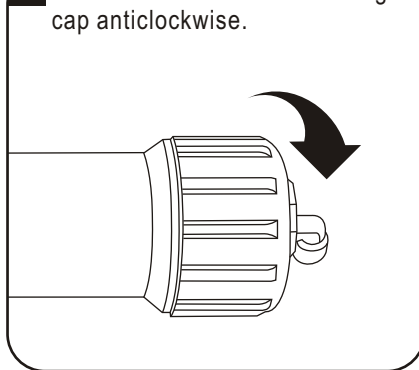

5 Remove the membrane by a pincer.

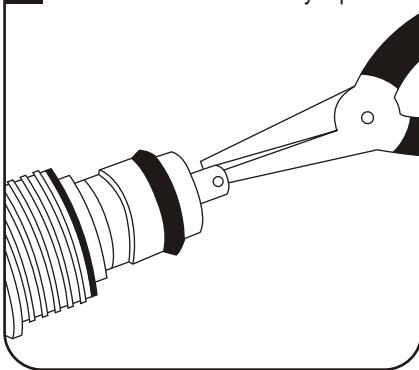

6 Install the membrane by carefully pushing the spigot end into the socket at the far end of the housing until completely in.

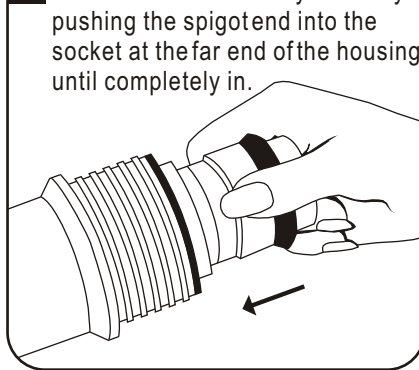

ROYAL Reverse Osmosis Drinking Water Systems

PUREPRO
DRINKING WATER SYSTEM

Tubing connection diagram

CONNECTING THE COLOR TUBING:

- A. Connect the WHITE tubing to the water supply connector.
- B. Connect the BLUE tubing to the sink top faucet.
- C. Connect the BLACK tubing to the drain saddle.
- D. Connect the RED tubing to the storage tank.

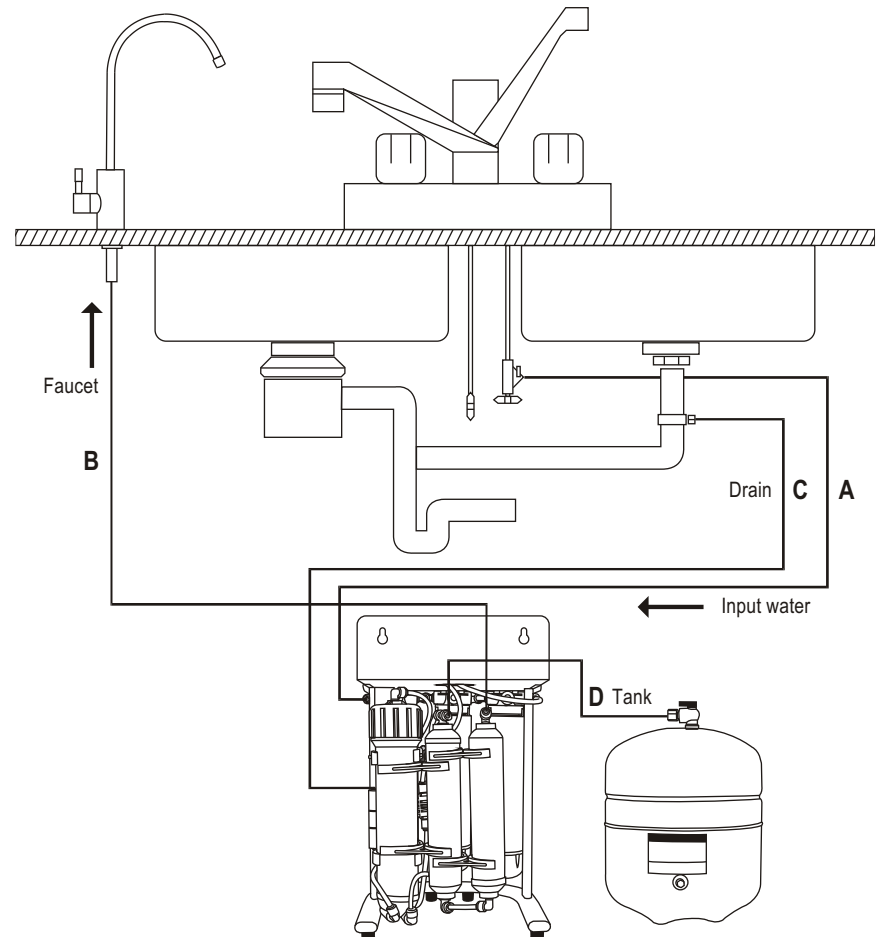

ROYAL Reverse Osmosis Drinking Water Systems

PUREPRO
DRINKING WATER SYSTEM

Installation diagram

Input water :

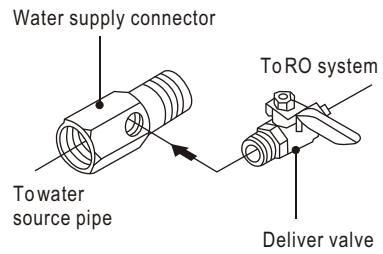

Install water tank :

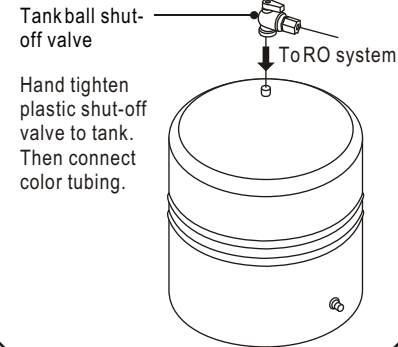

Install faucet :

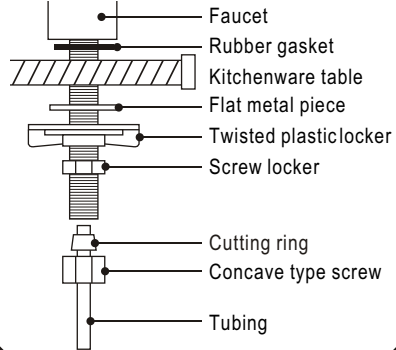

Install drain saddle :

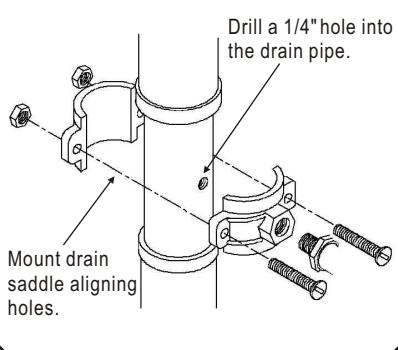

Assemble membrane :

- Remove the tube.
- Remove the membrane housing cap.
- Install the membrane by carefully pushing the spigot end into the socket at the far end of the housing until completely in.

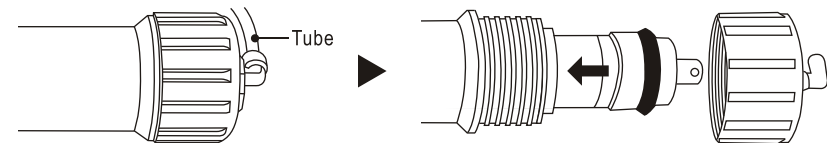

Change filters

