

Memo

Type of product			
Date of purchase			
Name		Tel	
Address			



REVERSE OSMOSIS SYSTEM

RS-106UV

USER'S MANUAL

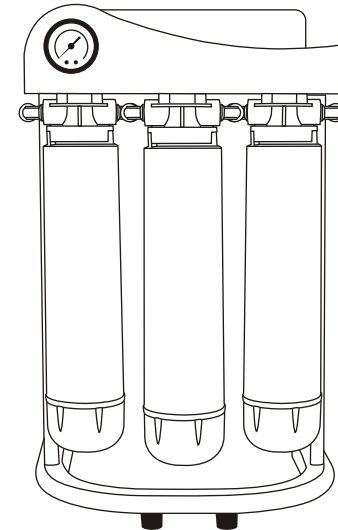

- 01 Introduction of RS-106UV
- 02 What is reverse osmosis
- 03 Components & Selected filters
- 04 Cartridge filters
- 05 The parts of RS-106UV
- 06 Tubing connection diagram
- 07 Installation diagram
- 09 Change filters
- 10 Change membrane
- 11 Operation regulation
- 13 FAQ
- 14 Maintenance checkinglist
- 15 Memo

Thank you very much for selecting Pure-Pro Water Corp.
In order to bring the best use of your system, please read the user's manual carefully before installation and follow the regulations.

FAQ

Q: What is the guarantee on the PurePro system ?

The PurePro system (excluding filters) is guaranteed for 1 year for material and workmanship. All defective parts will be replaced free within the first year under natural breakdown. The membrane has one year pro-rated guarantee.

Q: What factors affect the quantity and the quality of the water production?

There are four major variables to consider:

1. **Pressure**-The greater the water pressure, the better water quantity and quality it produced. Water pressure of 60 PSI is ideal.
2. **Temperature**-76°F is the ideal water temperature for R.O. 40°F water will cause the production of R.O. water to fall to half of that at 76°F. The maximum water temperature recommended is 85°F.
3. **Total Dissolved Solids (TDS)**-The higher the amount of dissolved contaminants in the water, the lower the quantity of water produced. A high level of TOTAL DISSOLVED SOLIDS can be overcome with additional water pressure.
4. **Membrane**-Different membranes have different characteristics. Some produce more water than others; some have better contaminant rejection capabilities; some have greater resistance to chemical abrasion for longer life. PurePro system includes TW30-1812-100 The Thin Film Composite (TFC) membranes combine the best of these characteristics and are considered the finest membrane in the world.

Q: Can the PurePro system be connected to an extra faucet?

It only takes a 1/4" tee and tubing to run the water to a refrigerator or a extra faucet. Some families run PurePro system to all of their bathrooms.

Q: What does the PurePro series drinking water taste like?

The taste of the PurePro water depends on the amount of contaminants in the tap water originally. If 95% of dissolved minerals and chemicals are removed, the R.O. water may taste like distilled water (no minerals), bottled water (low mineral), or natural spring water (moderate mineral content).

What is reverse osmosis

Reverse osmosis was originally designed to make sea water drinkable for the navy. It is ideal for anyone on a low sodium diet. An R.O. membrane has a pore size much smaller than bacteria virus, or the cryptosporidium parasite. When functioning properly it will remove all microorganisms from tap water and produce sterile water. Reverse osmosis is the reversal of the natural flow of osmosis. In a water purification system, the goal is not to dilute the salt solution, but to separate the pure water from the salt and other contaminants. When the natural osmotic flow is reversed, water from the salt solution is forced to pass through the membrane in the opposite direction by application of pressure-thus the term REVERSE OSMOSIS. Through this process, we are able to produce pure water by screening out the salts and other contaminants.

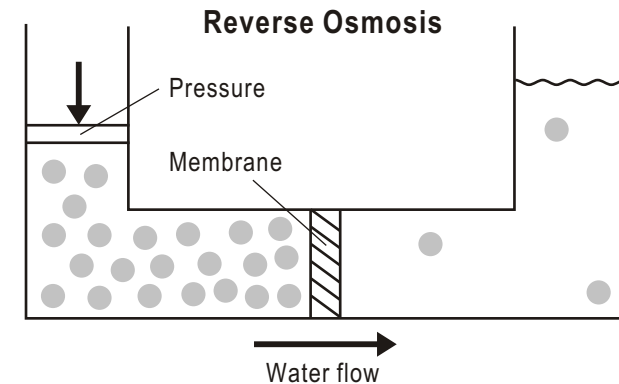

Components & Selected filters

Components

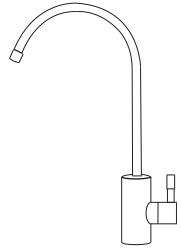

European ceramic faucet

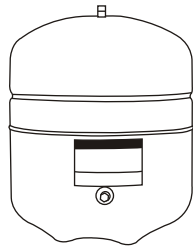

Water storage tank

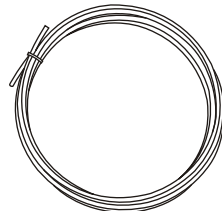

Tubing

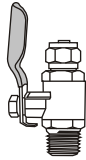

Deliver-valve

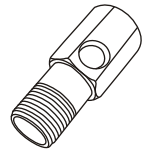

Water supply connector

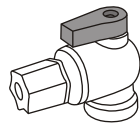

Tankball shut-off valve

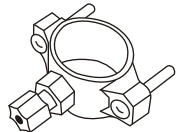

Drain saddle

Selected filters



Mineral cartridge filter

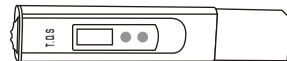

TDS meter

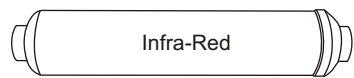

Infra-red cartridge filter



UV water sterilizer

ROYAL Reverse Osmosis Drinking Water Systems

PUREPRO
DRINKING WATER SYSTEM

Operation regulation

- A. With everything connected, turn on the water check for leaks.
- B. Make sure the storage tank shut-off valve is "OFF". Open the sink top faucet.
- C. Within a few minutes (up to 15) the water will start to run from the faucet slowly.
- D. Let the water run for at least 30 minutes. This flushes the carbon filters on first time use.
- E. After initial flushing, open the shut-off valve on the tank and close the sink top faucet.
- F. Tank will now full of water (usually 2 to 3 hours) after the tank has filled. Open the sink top faucet and drain all water until the storage tank is empty and there is only a small flow from the sink top faucet. *** DO NOT USE FIRST TANK OF WATER. ***
- G. Close the sink top faucet. The system is now ready for use.
- H. Change filters regularly every 6 to 12 months and have the membrane checked annually.

Caution

1. Do not use hot water (over 45°C)!
2. Do not freeze the machine!
3. Switch off electricity and water source if away for more than 5 days, and drain out pure water.

ROYAL Reverse Osmosis Drinking Water Systems

PUREPRO
DRINKING WATER SYSTEM

Operation regulation

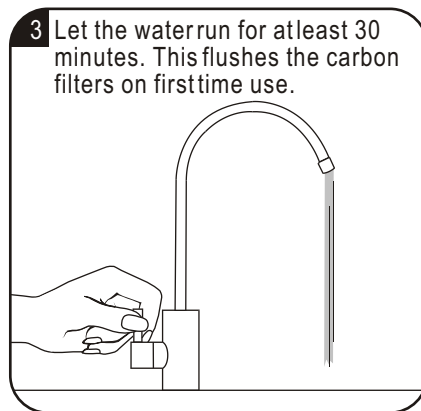
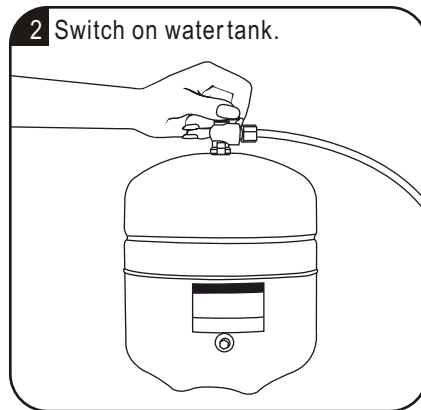
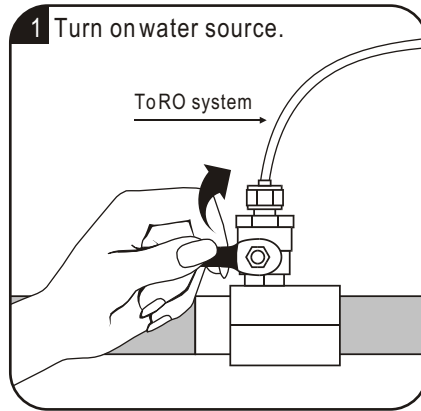

ROYAL Reverse Osmosis Drinking Water Systems

Cartridge filters

Cartridge Filters	Filter Description	Service Life
<p>Stage 1 5 Micron Sediment Filter</p>	<p>RS300ST With only five micron rating. It is effective in removing dirt, rust and sand particles.</p>	6 Months
<p>Stage 2 GAC Carbon Filter</p>	<p>RS300ND It takes out 99% of the chlorine and organic chemicals. It provides enhanced reduction of taste, odor, and color.</p>	6 Months
<p>Stage3 CTO Carbon Filter</p>	<p>RS300RD It takes out 99% of the chlorine and organic chemicals. It provides enhanced reduction of taste, odor, and color.</p>	6 Months
<p>Stage 4 TFC Membrane</p>	<p>A thin film composite (TFC) high quality membrane that processes 100 gallons per day. It remove the following hard water contaminants that may be present in your water: lead, cooper, barium, chromium, mercury, sodium, cadmium, fluoride, nitrite, nitrate, and selenium.</p>	2 Years
<p>Stage 5 Post Carbon Filter</p>	<p>NSF approved. This post carbon filter is designed to improve taste. It removes any residual impurities and odors from the tank and provides a finer conditioning of pure water.</p>	1 Year
<p>Stage 6 UV Water Sterilizer</p>	<p>1GPM Heavy duty stainless steel 304 pressure vessel. Heavy duty quartz sleeve. High output, hard glass UV lamps for maximum efficiency. CE ballast with lamp failure indicator and warning buzzer.</p>	1 Year

ROYAL Reverse Osmosis Drinking Water Systems

The parts of RS-106UV

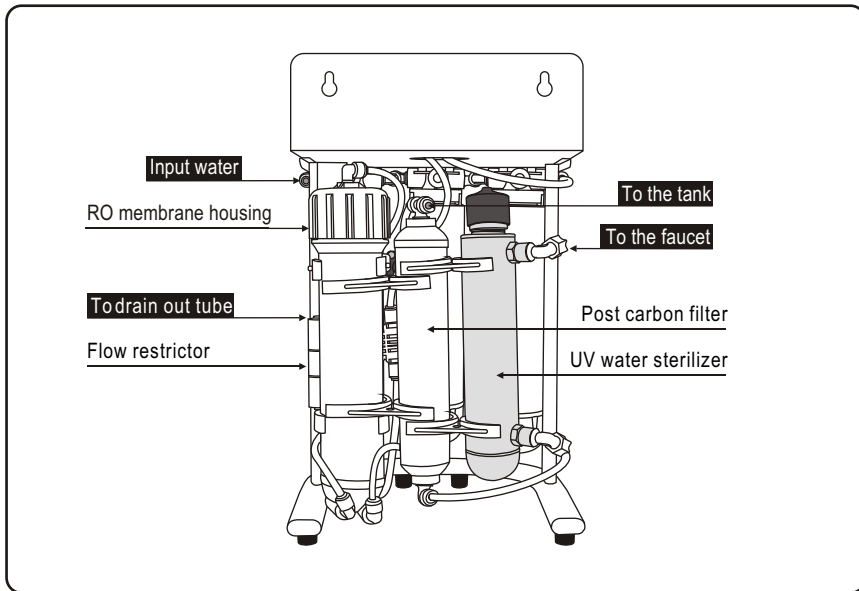
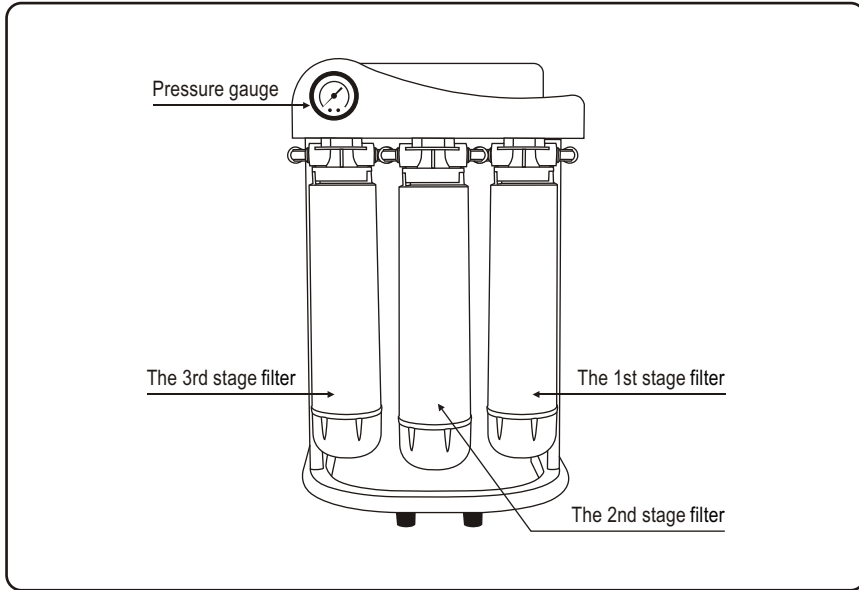

ROYAL Reverse Osmosis Drinking Water Systems

Change membrane

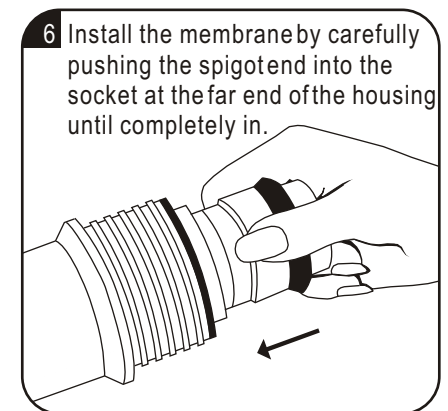
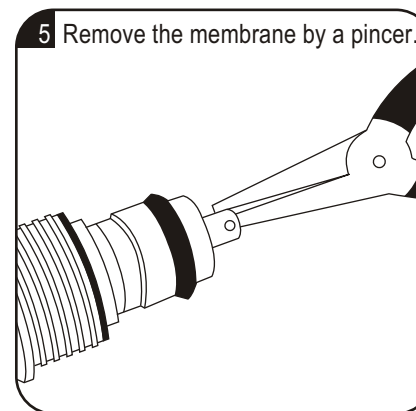
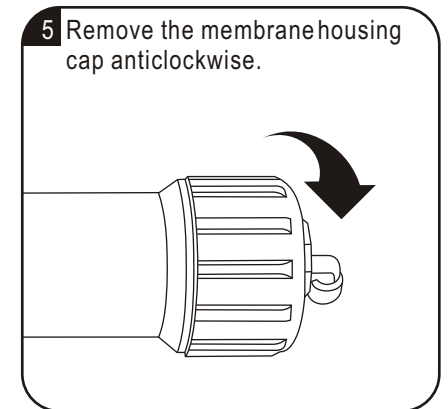
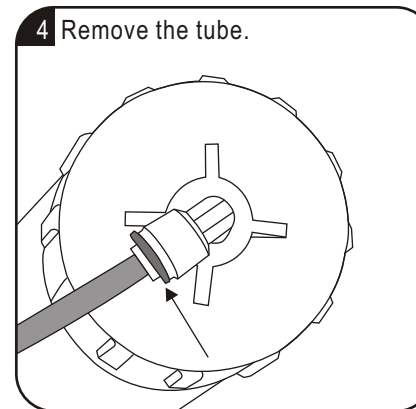
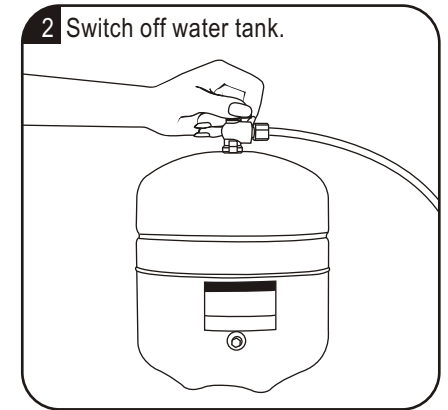
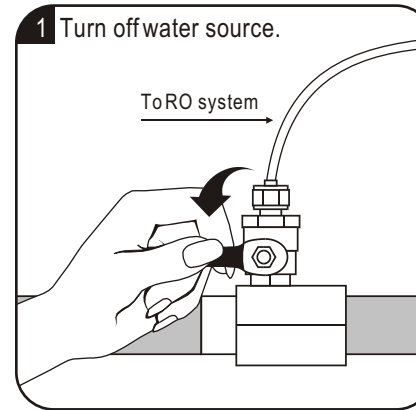

ROYAL Reverse Osmosis Drinking Water Systems

Change filters

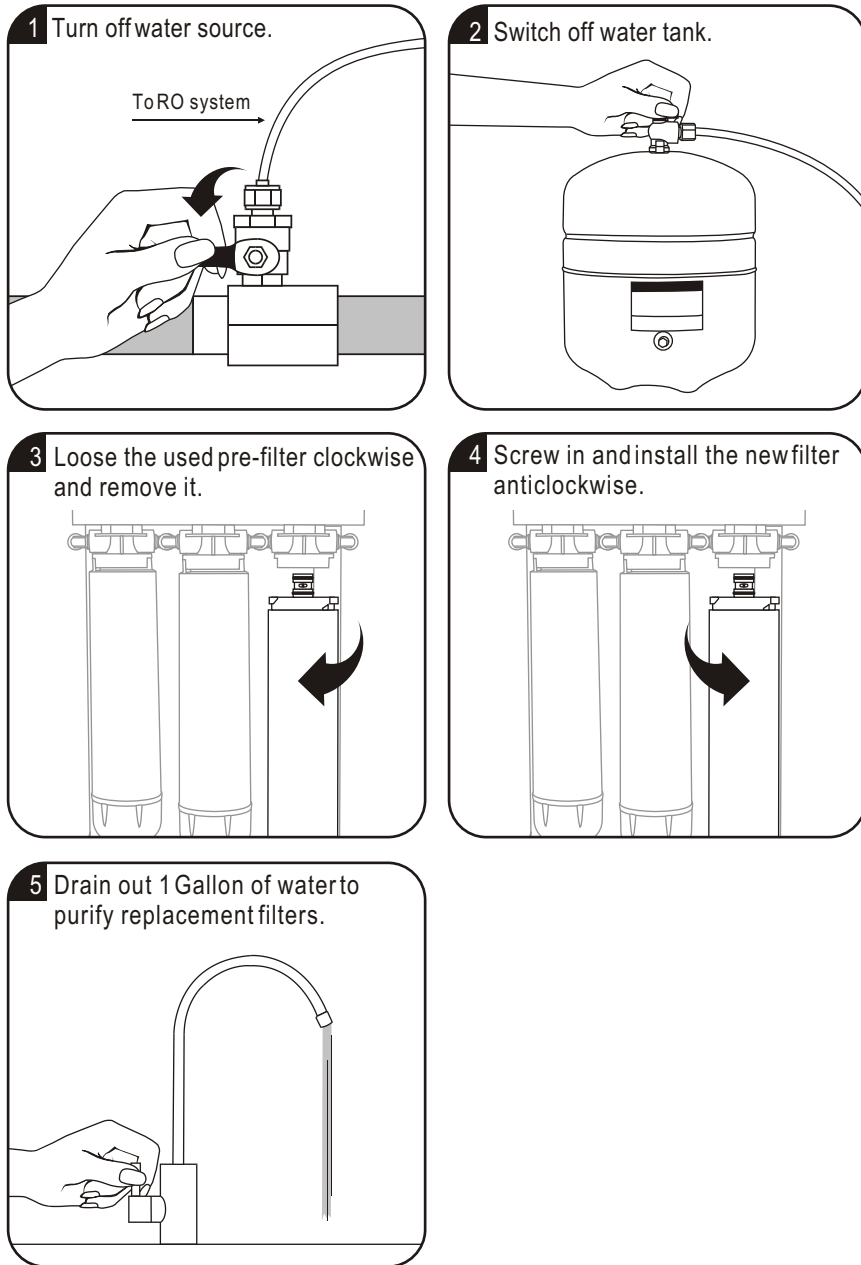

ROYAL Reverse Osmosis Drinking Water Systems

PUREPRO
DRINKING WATER SYSTEM

Tubing connection diagram

CONNECTING THE COLORTUBING:

- A. Connect the WHITE tubing to the water supply connector.
- B. Connect the BLUE tubing to the sink top faucet.
- C. Connect the BLACK tubing to the drain saddle.
- D. Connect the RED tubing to the storage tank.

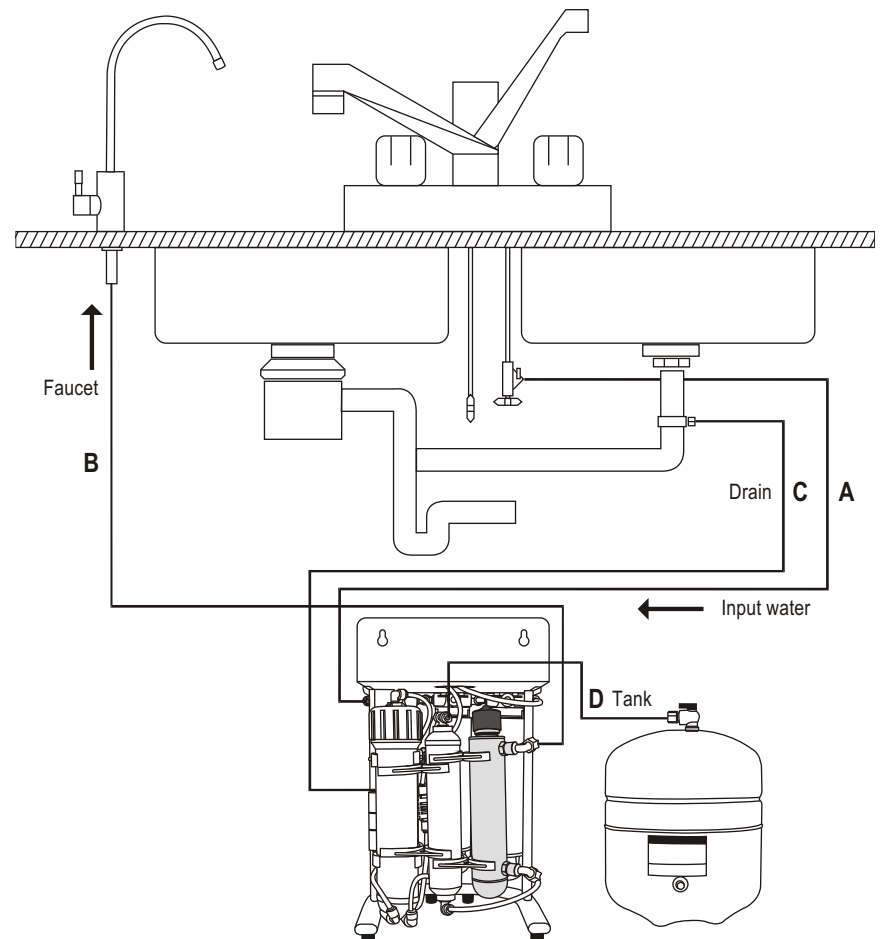

ROYAL Reverse Osmosis Drinking Water Systems

PUREPRO
DRINKING WATER SYSTEM

Installation diagram

Input water :

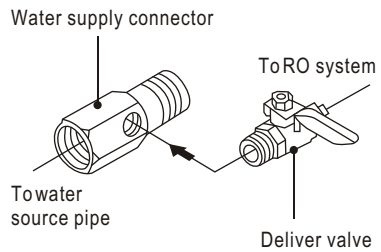

Install water tank :

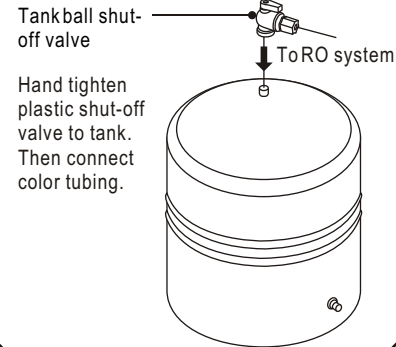

Install faucet :

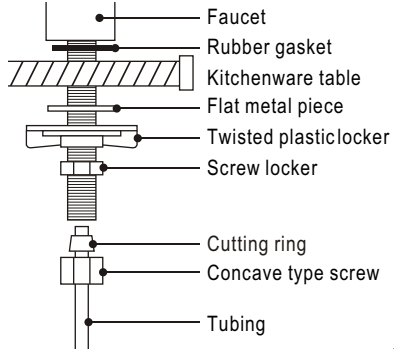

Install drain saddle :

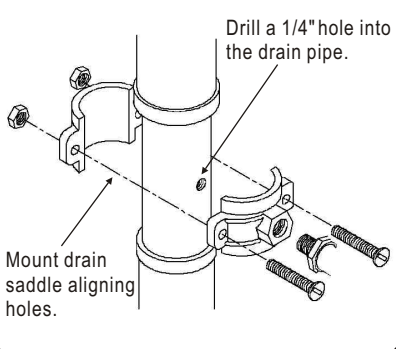

Assemble membrane :

- Remove the tube.
- Remove the membrane housing cap.
- Install the membrane by carefully pushing the spigot end into the socket at the far end of the housing until completely in.

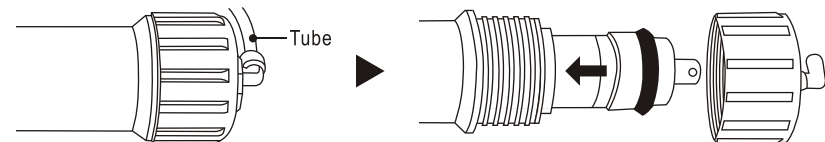

Installation diagram

Install UV lamp :

1. Take out the UV sterilizer from the box as shown in the picture.

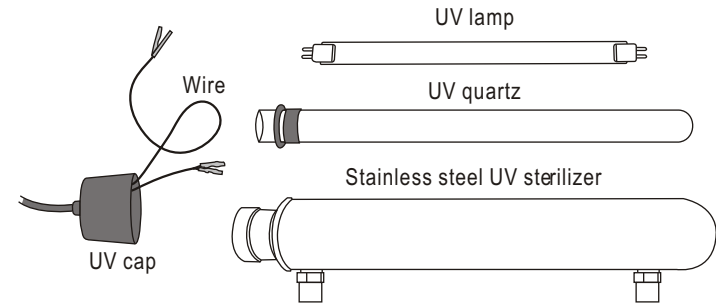

2. Open the cap and insert the UV quartz.

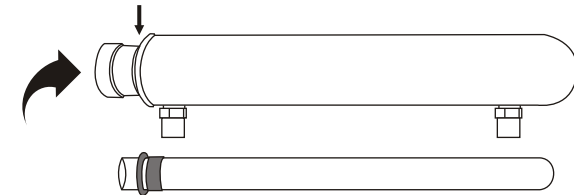

3. Connect the wire to both ends of UV lamp.

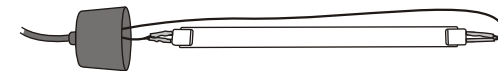

4. Tight up the UV cap.

