

Memo

Type of product			
Date of purchase			
Name		Tel	
Address			

PURE-PRO 07 REVERSE OSMOSIS SYSTEM

PUREPRO
DRINKING WATER SYSTEM

WATER FILTRATION SYSTEMS

CT2000

USER'S MANUAL

- 01 Introduction of CT2000
- 02 Cartridge filters
- 03 Components & Other selections
- 04 Tubing connection diagram
- 05 Installation diagram
- 06 Change filters

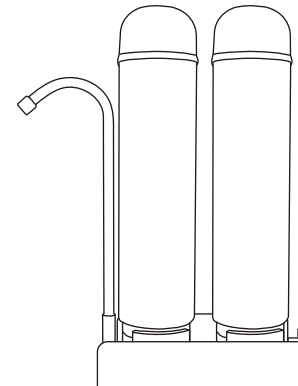

Thank you very much for selecting Pure-Pro Water Corp.
In order to bring the best use of your system, please read the user's manual carefully before installation and follow the regulations.

CT2000 Easy-change cartridge water filters

PUREPRO
DRINKING WATER SYSTEM

Introduction of CT2000

CT2000 Countertop water filters

Our CT2000 filters safely and effectively remove microorganisms like Giardia and Cryptosporidium from your water protecting you and your family from parasitic illnesses caused by these contaminants.

The patented quick-change filter technology also improves the taste and overall quality of your water by reducing the amount of Lead, Chlorine, Asbestos and other impurities often found in water supplies.

Efficient and easy to use, our CT2000 Countertop & Under sink Water Filters provide 1500 gallons (four to six months worth) of quality water and connecting directly to your tap, this water filtration product is convenient and practical. This unit will purify up to 1500 gallons of water by removing lead and other heavy metals as well as chlorine, bad tastes and odors.

Features

- Complete 2 stage water filter system.
- Use twist and quick-change cartridge design makes filter changes fast, clean and easy.
- Feed water connector & deliver valve
- Completely Assembled & Water leaking testing
- 100% Factory Tested and Sterilized Ready for Installation.

Specifications

- Dimensions: (cm) 17.0 (L) x 31.0 (H) x 9.0 (W)
- Weight: 3.5 kg

Change filters

1. Turn off water source.

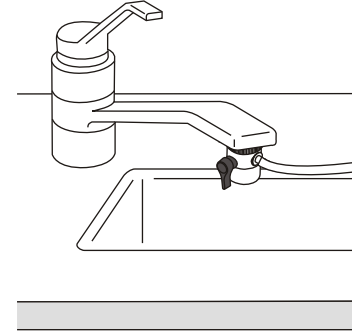

2. Loosen the used pre-filter anticlockwise and remove it.

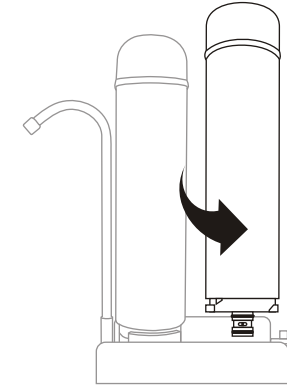

3. Screw in and install the new filter clockwise.

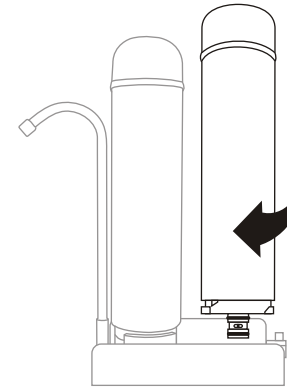

4. Turn on water supply.

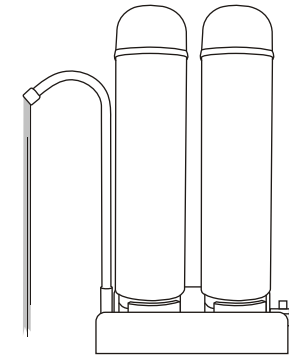

Drain out 1 Gallon of water to purify replacement filters.

Installation diagram

⊙ **Install faucet adaptor :**

Screw in the adaptor to the faucet head clock-wise; make sure it is connected to the faucet head.

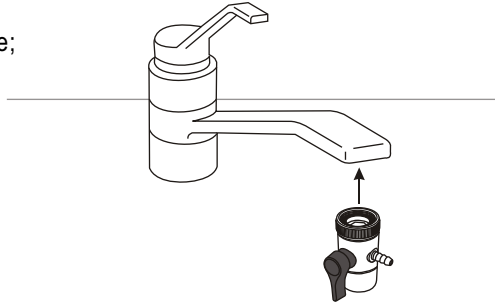

Cartridge filters

Filter Description

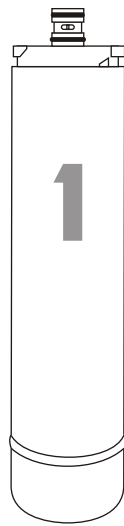
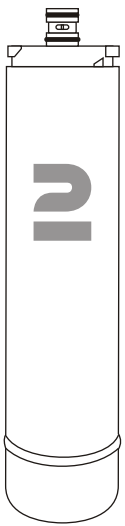
RS300ST	RS300ND
	
<p><u>Stage 1</u> 5 Micron Sediment Filter</p> <p>With only five micron rating. It is effective in removing dirt, rust and sand particles.</p>	<p><u>Stage 2</u> GAC Carbon Filter</p> <p>It takes out 99% of the chlorine and organic chemicals. It provides enhanced reduction of taste, odor, and color.</p>

Components & Other selections

Components

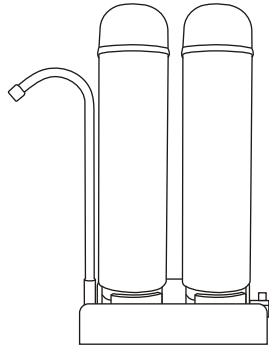

CT2000

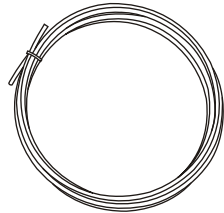

Tubing



Faucet adaptor

Other selections

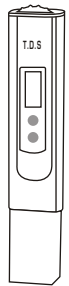

TDS meter

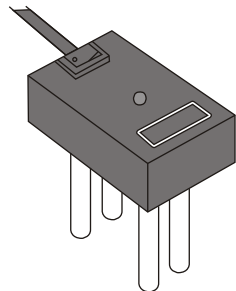

Electronic Color Tester



Shower filter

CT2000 Easy-change cartridge water filters

Tubing connection diagram

- 1 In Let
- 2 Out Let

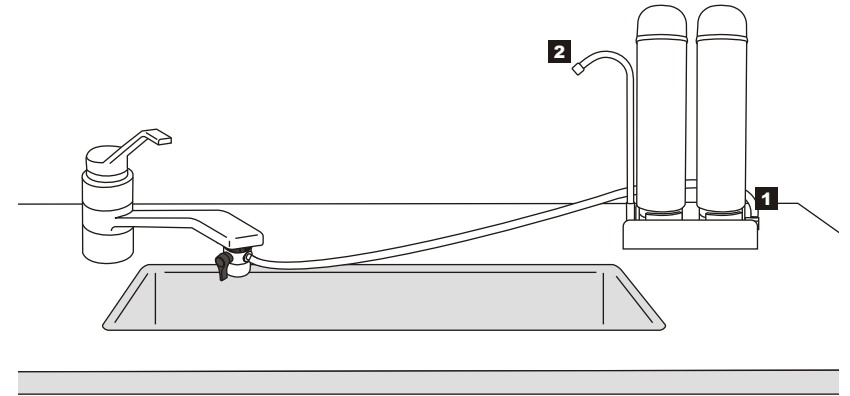

CT2000 Easy-change cartridge water filters