

# Memo

Type of product			
Date of purchase			
Name		Tel	
Address			

## REVERSE OSMOSIS SYSTEM

# RO600

## USER'S MANUAL

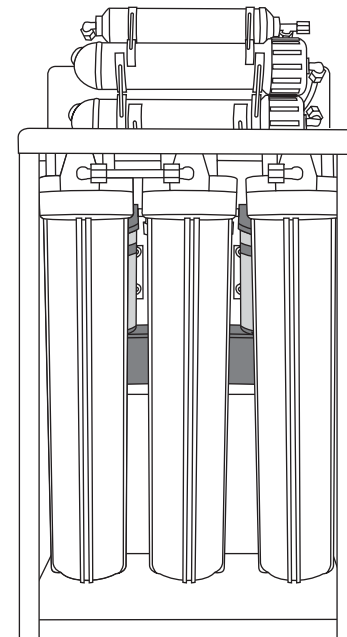

- 01 Introduction of RO600
- 02 What is Reverse Osmosis
- 03 Components & Selections
- 04 Cartridge filters
- 05 The parts of RO600
- 07 Tubing connection diagram
- 08 Installation diagram
- 13 Change filters
- 14 Change RO membrane
- 15 Operation regulations
- 17 FAQ
- 18 Maintenance checking list
- 19 Memo

**Thank you very much for selecting Pure-Pro Water Corp.**  
In order to bring the best use of your system, please read the user's manual carefully before installation and follow the regulations.

# Introduction of RO600

◆ **RO600**

This system is economical and designed for commercial and residential application. Provide safe, pure water. It is suitable for manufacturing, restaurants, food processing industries, shopping centers, schools and hotels.

RO600 improves both the taste and quality of your water. It reduces up to +99% of the chlorine, as well as objectionable odors and sediment. RO600 also reduces the following hard water contaminants that may be present in your water: lead, cooper, barium, chromium, mercury, sodium, cadmium, fluoride, nitrite, nitrate, and selenium.

◆ **Features**

- 20 Gallons Standards Water Storage Tank With Tank Ball Valve.
- FDAApproved Polypropylene Made Flat Cap Housings.
- 3 high rejection membranes, Each membrane is 200GPD at 100psi.
- Build in electrical shut off valve to prevent any damage of the membrane.
- Self Piercing Saddle Valve & Feed water quick connector.
- Drain Saddle Valve.
- 1 Year Warranty.
- 30 Days Money Back Guarantee.
- Completely Assembled, 100% Factory Tested and Sterilized Ready for Installation.

◆ **Specifications**

- Production: 600gpd
- Water Tank (Include) : 20 gallons.
- Operation Pressure : 10 - 125 psi
- Available in : 110 volt, 220volt, 240volt. ( 50 / 60 Hz )
- Weight (System & Tank) : 49 kg
- Dimensions: 50.0 (L) x 24.0 (W) x 80.0 (H) cm - system  
56.0 (L) x 56.0 (W) x 88.0 (H) cm - tank

PURE-PRO 01 REVERSE OSMOSIS SYSTEM

RO600 600GPD Light Commercial



# Maintenance checking list

Filters Date	1st stage	2nd stage	3rd stage	4th stage & 6th stage	7th stage	Other items

PURE-PRO 18 REVERSE OSMOSIS SYSTEM

RO600 600GPD Light Commercial



## FAQ

### Q: What is the guarantee on the PurePro system ?

The PurePro System (excluding filters) is guaranteed for 1 year for material and workmanship. All defective parts will be replaced free within the first year under natural breakdown. The membrane has one year pro-rated guarantee.

### Q: What factors affect the quantity and the quality of the water production?

There are four major variables to consider:

1. **Pressure**-The greater the water pressure, the better water quantity and quality it produced. Water pressure of 60 PSI is ideal.
2. **Temperature**-76°F is the ideal water temperature for R.O. 40°F water will cause the production of R.O. water to fall to half of that at 76°F. The maximum water temperature recommended is 85°F.
3. **Total Dissolved Solids (TDS)**-The higher the amount of dissolved contaminants in the water, the lower the quantity of water produced. A high level of TOTAL DISSOLVED SOLIDS can be overcome with additional water pressure.
4. **Membrane**-Different membranes have different characteristics. Some produce more water than others; some have better contaminant rejection capabilities; some have greater resistance to chemical abrasion for longer life. PurePro system includes TW30-1812-200 The Thin Film Composite (TFC) membranes combine the best of these characteristics and are considered the finest membrane in the world.

### Q: My RO system is not making any water. What should I do?

1. Make sure you plug in electricity.
2. Check the water supply. Make sure it's on.
3. Check if pumps work well.

If none of above occur, please contact a technician at the nearest shop for assistance.

### Q: Why can't my water storage tank make enough water?

1. Switch off the water supply and turn on the faucet.
2. Check the water flow from the faucet. If water stop coming out, check the water storage tank.

Water tank still has water: the tank water pressure is under regular water pressure → give pressure to the tank.

## What is reverse osmosis

Reverse osmosis was originally designed to make sea water drinkable for the navy. It is ideal for anyone on a low sodium diet. An R.O. membrane has a pore size much smaller than bacteria virus, or the cryptosporidium parasite. When functioning properly it will remove all microorganisms from tap water and produce sterile water. Reverse osmosis is the reversal of the natural flow of osmosis. In a water purification system, the goal is not to dilute the salt solution, but to separate the pure water from the salt and other contaminants. When the natural osmotic flow is reversed, water from the salt solution is forced to pass through the membrane in the opposite direction by application of pressure—thus the term REVERSE OSMOSIS. Through this process, we are able to produce pure water by screening out the salts and other contaminants.

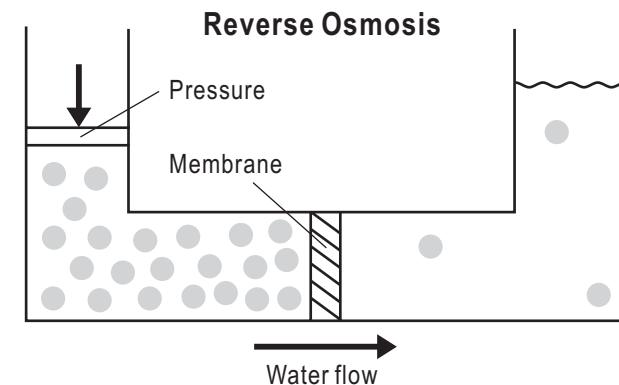

## Components & Selections

### ◆ Components

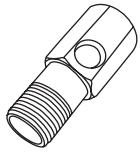

Feed water connector

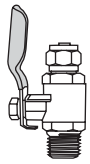

Deliver-valve

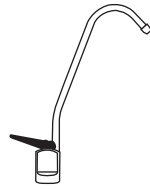

Standard faucet



RO membrane x 3

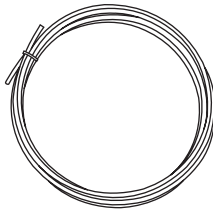

Tubing white

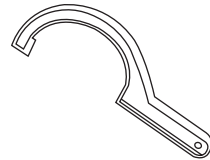

Housing wrench C-type

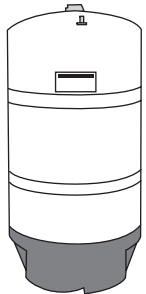

20G water storage tank

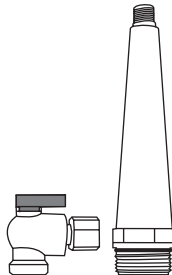

Tank ball valve

### ◆ Selections

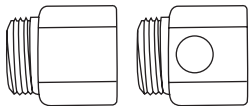

1. 6/8 hot & cold water deliver-valve

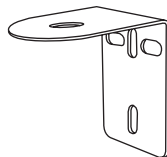

2. standing faucet bracket

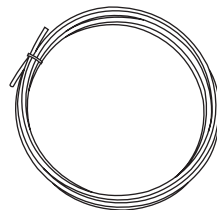

3. 3/8 extended RO tubing white

## Operation regulation

- A. With everything connected, turn on the water check for leaks.
- B. Make sure the storage tank shut-off valve is "OFF". Open the sink top faucet.
- C. Within a few minutes (up to 15) the water will start to run from the faucet slowly.
- D. Let the water run for at least 30 minutes. This flushes the carbon filters on first time use.
- E. After initial flushing, open the shut-off valve on the tank and close the sink top faucet.
- F. Tank will now full of water (usually 2 to 3 hours) after the tank has filled. Open the sink top faucet and drain all water until the storage tank is empty and there is only a small flow from the sink top faucet. \*\*\* DO NOT USE FIRST TANK OF WATER.\*\*\*
- G. Close the sink top faucet. The system is now ready for use.
- H. Change filters regularly every 6 to 12 months and have the membrane checked annually.

### Caution

1. Do not use hot water (over 45°C)!
2. Do not freeze the machine!
3. Switch off electricity and water source if away for more than 5 days, and drain out pure water.

# Operation regulation

1 Plug in electricity.

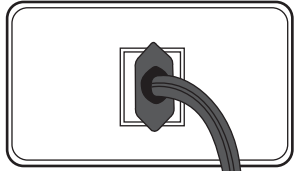

2 Turn on water source.

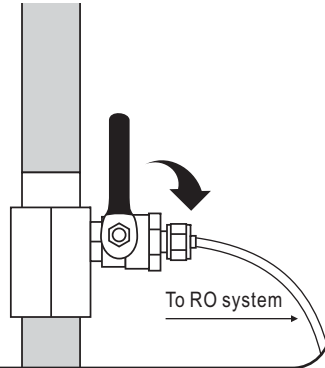

3 Turn on water tank supply.

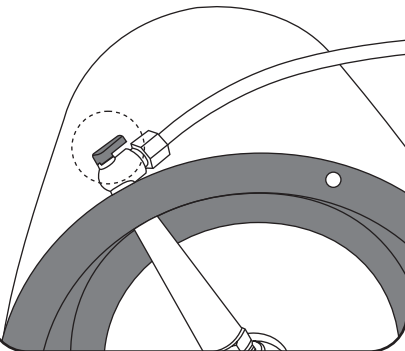

4 Pumps start to function.

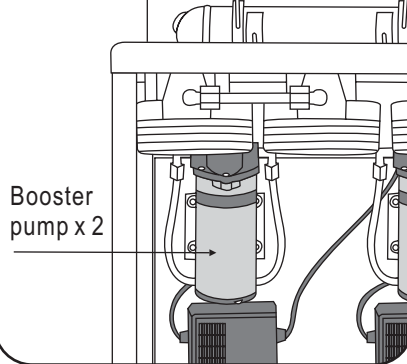

Booster pump x 2

5 For the first time operation when changing the filters, water should run for at least 20 minutes before drinking it.

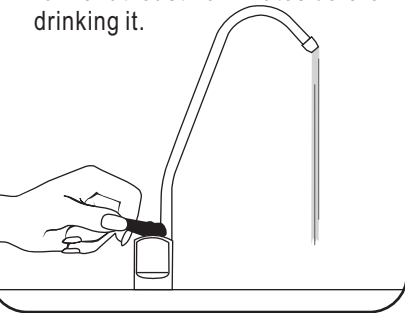

# Cartridge Filters

Cartridge Filters	Filter Description	Service Life
<p><b>Stage 1</b> 20" length 5 micron Spun-polypropylene Sediment Filter</p>	<p>This 5micron sediment filter is made of 100% pure polypropylene fibers. High capacity filter removes dusts, particles and rusts.</p>	3 Months
<p><b>Stage 2</b> 20" length Granular Activated Carbon Filter</p>	<p>This granular activated carbon filter is composed of high-performance activated carbon that removes free chlorine, odor, organic contaminants, pesticides and chemicals that contributed to taste and odor.</p>	3 Months
<p><b>Stage 3</b> 20" length Block Carbon Filter</p>	<p>This block carbon filter is composed of high-performance carbon that removes free chlorine, odor, organic contaminants, pesticides and chemicals that contributed to taste and odor.</p>	3 Months
<p><b>Stage 4~6</b> 200GPD TFC membrane 3 pcs</p>	<p>Made in USA. High rejection TFC type membrane with the capacity of producing 200 gallons per day. This membrane removes the following hard water contaminants that may be present in your water: lead, copper, barium, chromium, mercury, sodium, cadmium, fluoride, nitrite, nitrate, and selenium.</p>	1 Year
<p><b>Stage 7</b> 12" Inline Post Carbon Filters</p>	<p>NSF approved. This post carbon filter is designed to improve taste. It removes any residual impurities and odors from the tank and provides a finer conditioning of pure water.</p>	1 Year

# The parts of RO600

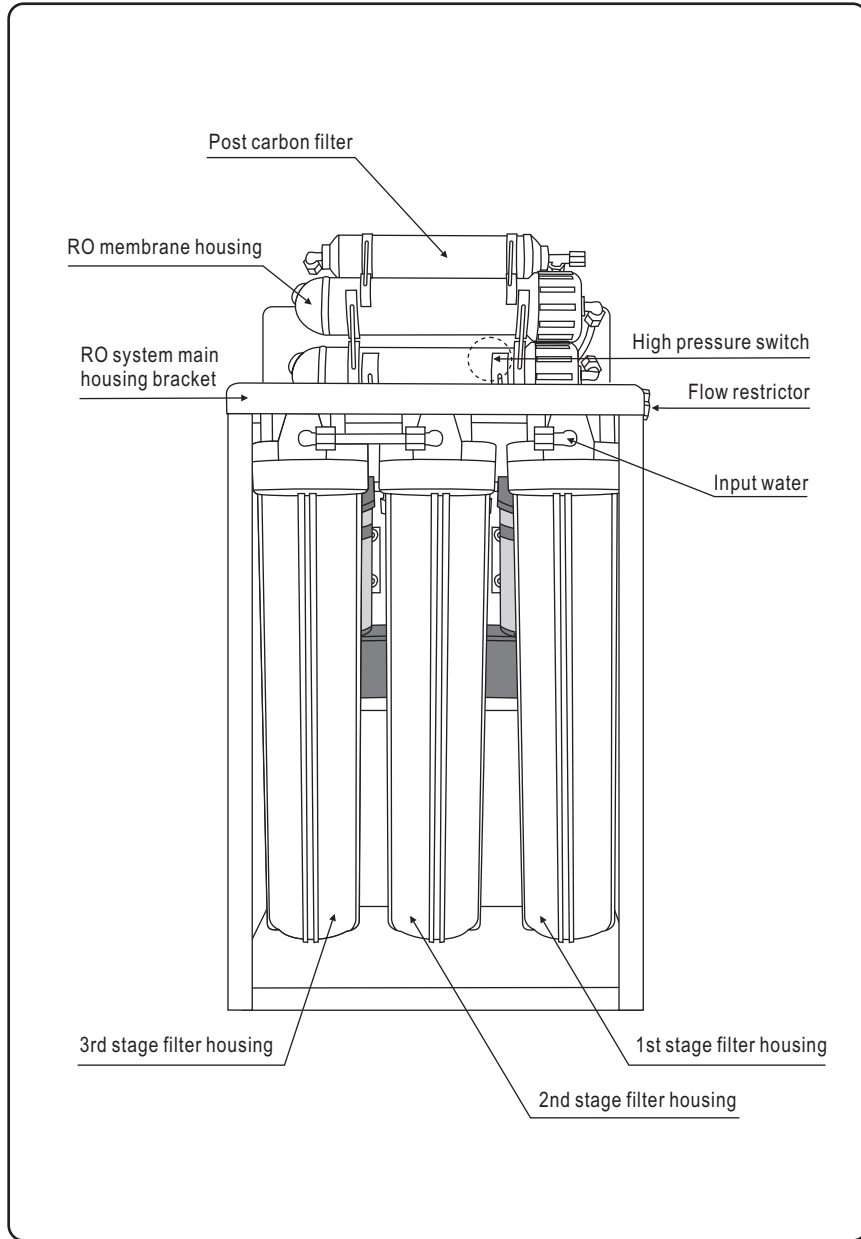

RO600 600GPD Light Commercial

# Change membrane

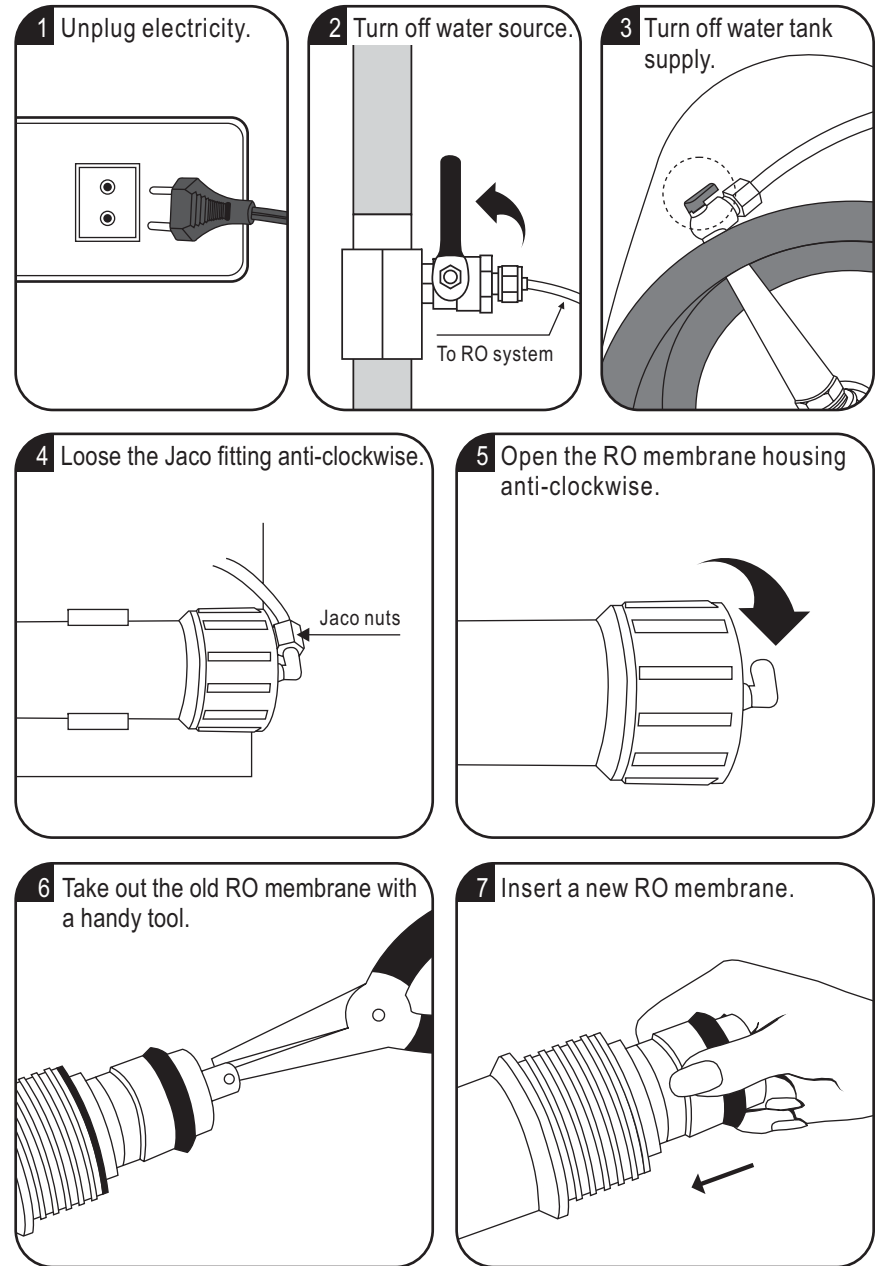

RO600 600GPD Light Commercial

## Change filters

1 Have a C-type housing wrench ready.

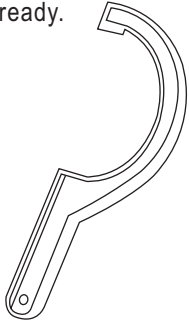

2 Turn off water source.

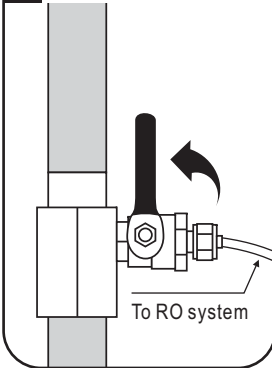

3 Turn off water tank supply.

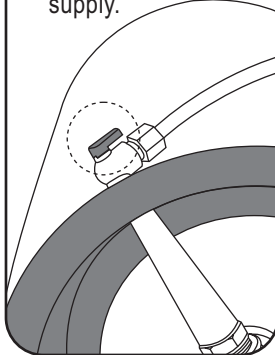

4 Unplug electricity.

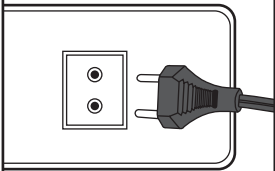

5 Open the housings clockwise.

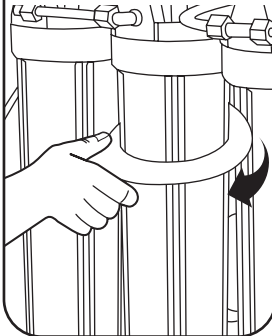

6 Insert new filter.

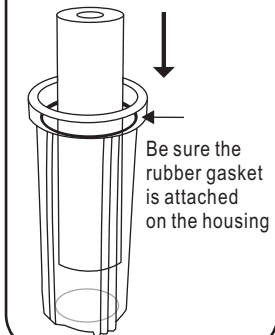

7 Loosen the fitting nuts at point 1, 2, 3. Take out the jaco fittings, and seal it up with the Teflon tape again. Replace the new pre-filters.

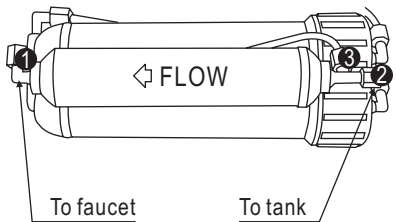

8 After changing filters, let water run for about 15 minutes to clear the filters.

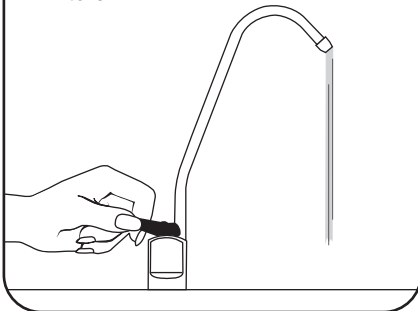

RO600 600GPD Light Commercial

**PUREPRO**  
DRINKING WATER SYSTEM

## The parts of RO600

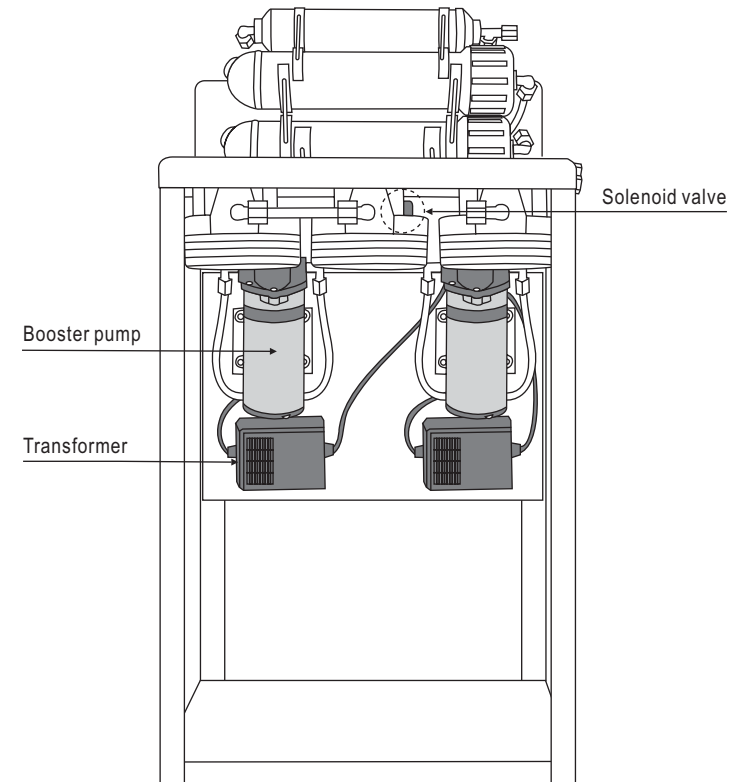

RO600 600GPD Light Commercial

**PUREPRO**  
DRINKING WATER SYSTEM

# Tubing connection diagram

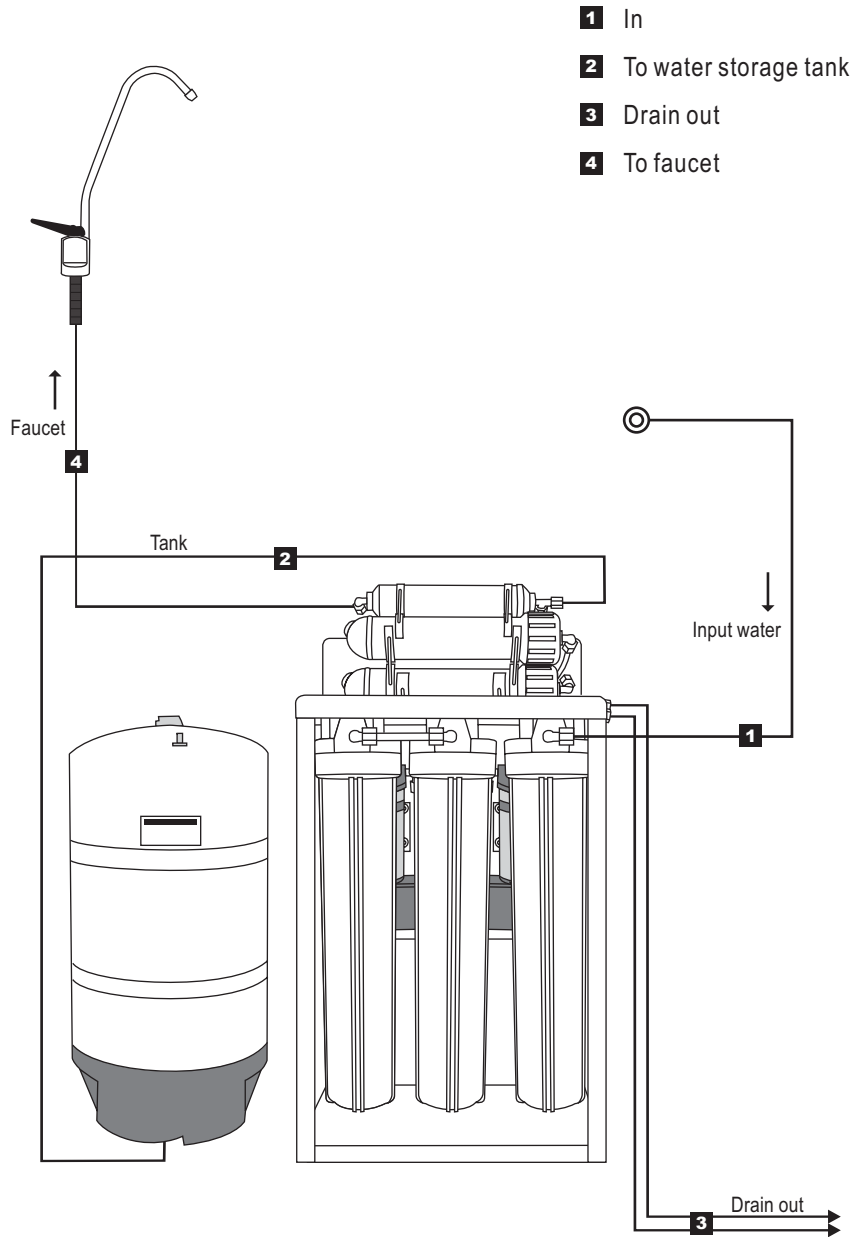

RO600 600GPD Light Commercial

# Installation diagram

11. Take tubing white. Wear the concave type screw on tubing white and insert the tubing shroud as shown in the picture. Connect the tubing top with the faucet end. Then connect the tubing end to the last stage filter (as point 4 on page 07)

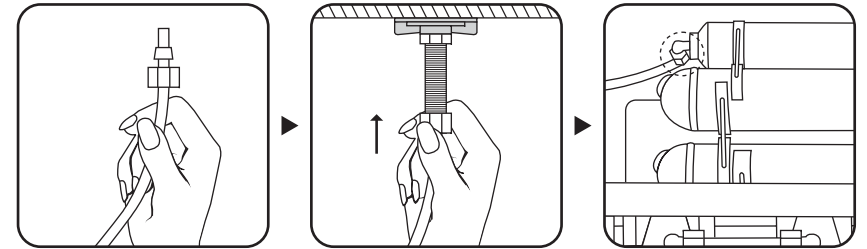

12. Make sure that you complete No. 1 to No. 11. If so, switch on water supply and plug in electricity.

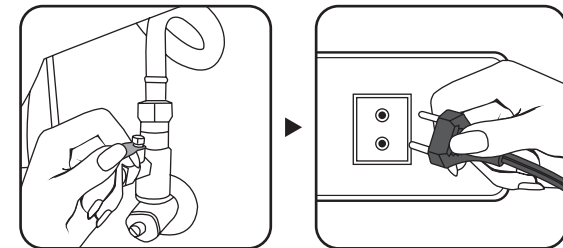

PS. Do not use drink water from the first made water in the tank.

RO600 600GPD Light Commercial



## Installation diagram

10. Take out the faucet and its components. Install the faucet and the rubber gasket to the kitchenware table. Install the rest of component as shown in the picture.

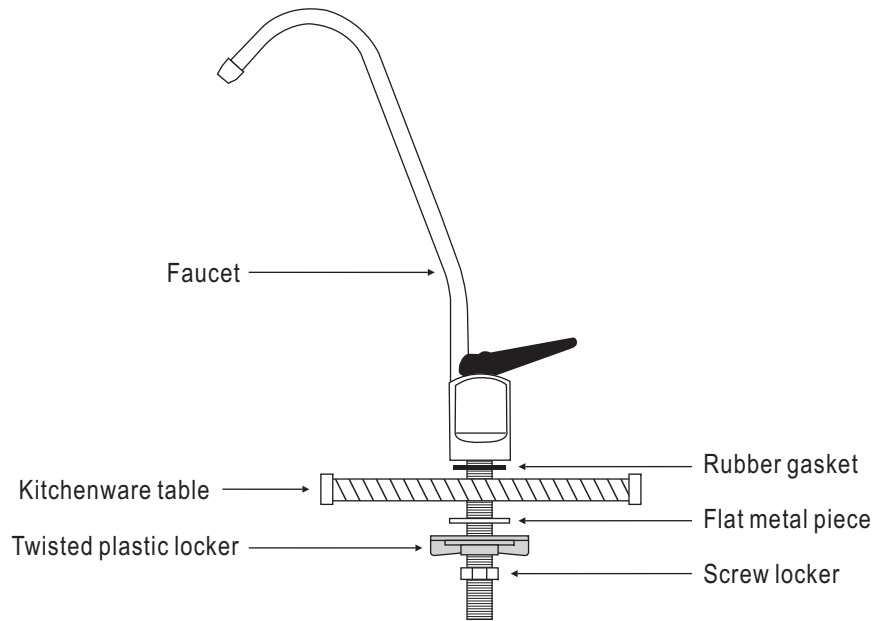

PS. To suit your kitchenware table, you can choose to have twisted plastic locker or screw locker to be installed for your faucet.

## Installation diagram

1. Loosen the fitting nuts and the cap from the RO membrane housing as shown in the picture. Unpack the RO membrane and insert it to its housing (rubber gasket towards to the open end). When completed, tighten up the cap with the RO membrane housing and the jaco fittings.

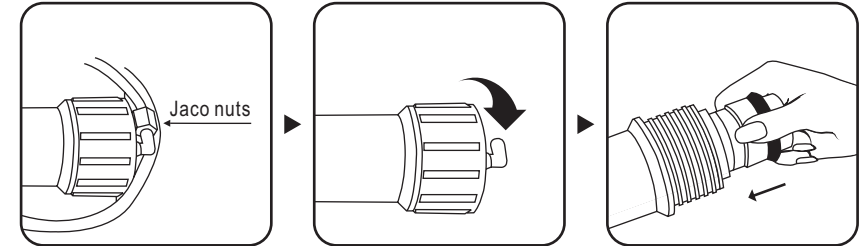

2. Turn off the water supply. Loosen the stainless steel pipe connector.

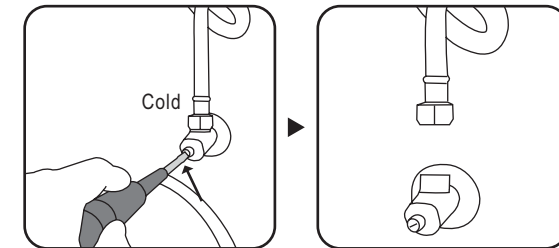

3. Get feed water connector and connect it to the stainless steel pipe as in the picture 2.

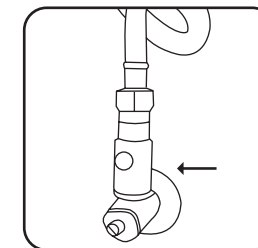

## Installation diagram

4. Get deliver valve and seal it with Teflon tape for 14 circles. Then connector it with the feed water connector.

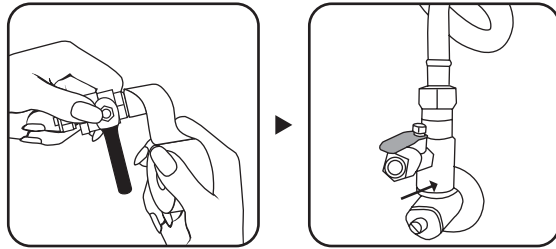

5. Get tubing white, connect it with deliver valve and the inlet water supply (as point 1 on page 07)

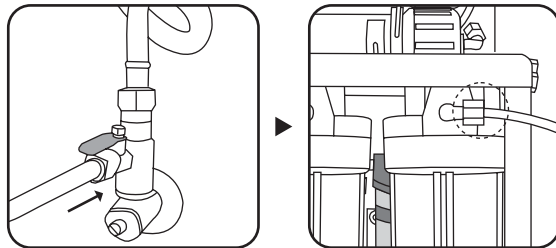

6. Screw in ball valve connector as shown in the picture.

Before jointing the tank ball valve, seal ball valve connector with Teflon tape.

Now put tank ball valve and its connector together.

※ Note: Teflon tape is required for every joint point.

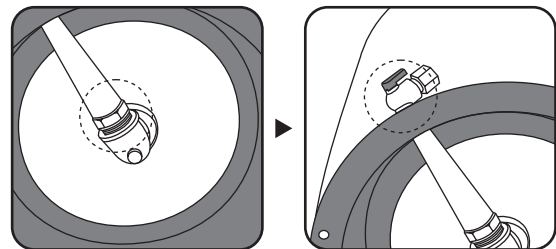

RO600 600GPD Light Commercial

**PUREPRO**  
DRINKING WATER SYSTEM

## Installation diagram

7. Take tubing white, connect it to the deliver valve and the inlet water to storage tank (as point 2 on page 07)

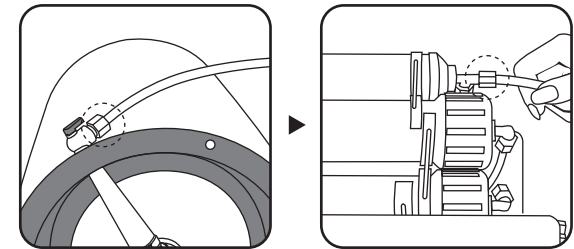

8. Take tubing white again, connect it with the drain out (as point 3 on page 07)

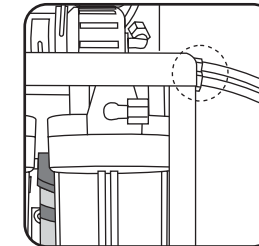

9. Use an electric drill and drill an approximately 1 cm hole through the kitchenware table.

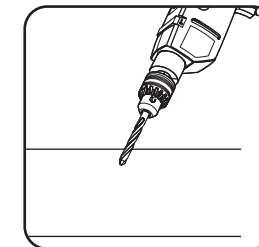

RO600 600GPD Light Commercial

**PUREPRO**  
DRINKING WATER SYSTEM