

Memo

Type of product	UV-301		
Date of purchase			
Name		Tel	
Address			



REVERSE OSMOSIS SYSTEM

UV-301

USER'S MANUAL

- 01 Introduction of UV-301
- 02 How UV works
- 03 Components & Other selections
- 04 Cartridge filters
- 05 The parts of UV-301
- 06 Tubing connection diagram
- 07 Installation diagram
- 08 Change filters
- 09 Operation regulation
- 11 FAQ
- 13 Maintenance checking list
- 15 Memo

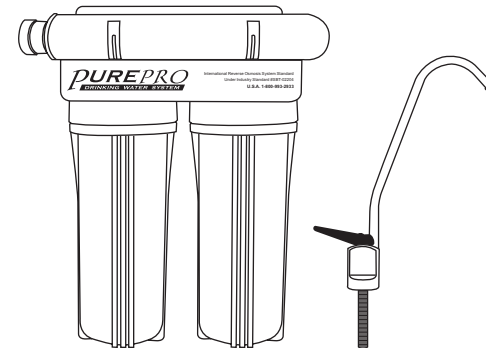

Thank you very much for selecting Pure-Pro Water Corp.
In order to bring the best use of your system, please read the user's manual carefully before installation and follow the regulations.

Introduction of UV-301

◆ UV-301- 3 stage Ultraviolet (UV) Water Purification System

Mini but super efficient! This system has an ultraviolet lamp capable of killing 99.99% of all bacteria and viruses. This system also removes the following 17 hazardous metals such as lead and mercury, insecticides, pesticides, radon, chlorine, bad taste and odor, as well as the single cell amoeba, Giardia and Cryptosporidium. The UV light of wavelengths between 250 and 270 nanometers (UV-C or UVC band), and is extremely effective in killing many species of bacteria, mold spores, viruses and other microorganisms. No longer fear drinking water from your own faucet!

◆ Specifications

- 3 Stage UV filtration system
- 100% Factory tested and sterilized ready for installation
- Heavy duty steel with powder coating white bracket
- UV stainless steel housing
- Double o'ring filter housing
- Feed water connector or self piercing saddle valve
- Completely assembled
- Long reach chrome faucet (upgrade faucet is acceptable)
- Installation Instruction
- Production: 1 GPM / 3.8 liters per minute
- Operation pressure: 15 -85 PSI
- Dimensions: (cm) 37 (L) x 20 (W) x 45(H)
- Weight: 6.0 kg

Maintenance checking list

Filters Date	1st stage	2nd stage	3rd stage	Other items

Maintenance checking list

Filters	1st stage	2nd stage	3rd stage	Other items
Date				

PURE-PRO 13 REVERSE OSMOSIS SYSTEM



How UV works

Using UV radiation in this manner to purify water is popular among Europeans who have known about it for decades. It's used in the United States started in the early 1990s and is becoming more prevalent especially with outbreaks of drinking water contamination by microorganisms. The UV purification system incorporates a lamp of suitable size and wattage to generate light of the proper wavelength with an electronic ballast to operate it. The electronic ballast plays an important role in how much UV the lamp generates. Dosage is a function of UV wavelength, intensity and time. Light intensity from the lamp is proportional to the electric current flowing through it, and is also affected by the frequency at which it's operated. Both of these parameters are controlled by the electronic ballast. Since many water purification systems are portable, they sometimes require power supplied from a battery rather than the typical AC source, i.e., 220-volt outlet. The electronic ballast must be able to accommodate applications with this requirement. Some of the other features users might expect from the electronic ballast are small physical size, long life and high efficiency.

At least one line of electronic ballasts can help meet these requirements. It can operate a wide variety of germicidal lamps from a number of different power supply voltages including both AC and DC (battery) sources. Many models are compact in size and can be easily incorporated into most designs. Probably one of the most attractive features of the product line is that nearly any model can be customized for a specific lamp to generate different levels of UV radiation. In some cases, new or specialty lamps require new ballast designs. In these instances, engineers can often create designs that meet or exceed customer needs. UV irradiation is becoming a more viable and economical means of water purification when used in conjunction with other methods.

PURE-PRO 02 REVERSE OSMOSIS SYSTEM



Components & Other selections

◆ Components

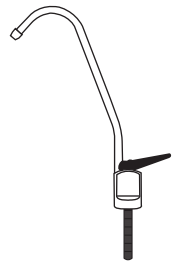

Standard faucet

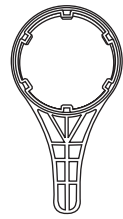

Housing wrench

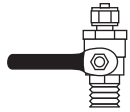

Deliver-valve

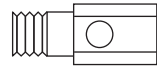

Water supply connector

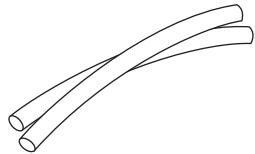

Four color coded 1/4 inch tubing for system connection

◆ Other selections

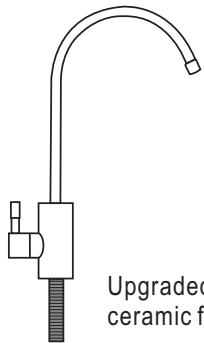

Upgraded european ceramic faucet

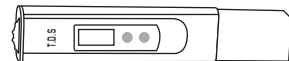

TDS meter

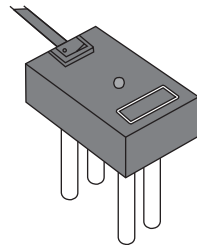

Color Tester

UV-301 3 Stage Ultraviolet (UV) Water Purification System

FAQ

Q: How will the Pure-Pro series water affect mixed beverages?

Because reverse osmosis removes invisible contaminants that mask flavor, it allows the natural taste of your beverages to come through. You will be able to use less coffee and still get the full flavor. Concentrated beverages like orange juice will taste tangier. You will probably be drinking a lot more water as well, since many people drink soda, Kool-Aid, concentrated juices, and beer as an alternative to bad-tasting tap water. Also, Pure-Pro eliminates most of the lime build up on drip coffee makers, preventing the need for frequent cleaning. No longer will you find the white scum on the inside of pans after boiling water.

Q: How much water does the Pure-Pro system produce ?

Under ideal conditions, the RE1812-70 TFC membrane is rated at 70gallons of production per day (70gpd at 60psi, 95gpd at 100psi). Under the average conditions, the consumer can expect 70-95 gallons of product water per day. But that's still a lot of water for the average household's drinking and cooking requirements.

Q: Don't people need minerals removed from the water ?

Most of the minerals that we receive are from the foods we eat. Only a very small percentage comes from the water we drink.

Q: What is the maintenance schedule for the Pure-Pro System ?

The three pre-filter cartridges should be changed every 6 months. The 5 micron sediment cartridge filter is the first one; the second is a carbon cartridge filter, and the third one is a 1 micron sediment filters. (some systems comes with the Extruded carbon filter.) Failure to change the cartridge every 6 months may cause chlorine to destroy the membrane.

UV-301 3 Stage Ultraviolet (UV) Water Purification System

FAQ

Q: What is the guarantee on the Pure-Pro system ?

The Pure-Pro System (excluding filters) is guaranteed for 1 year for material and workmanship. All defective parts will be replaced free within the first year under natural breakdown. The membrane has one year pro-rated guarantee.

Q: What factors affect the quantity and the quality of the water production?

There are four major variables to consider:

- 1.Pressure**-The greater the water pressure, the better water quantity and quality it produced. Water pressure of 60 PSI is ideal.
- 2.Temperature**-76°F is the ideal water temperature for R.O. 40°F water will cause the production of R.O. water to fall to half of that at 76°F. The maximum water temperature recommended is 85°F.
- 3.Total Dissolved Solids (TDS)**-The higher the amount of dissolved contaminants in the water, the lower the quantity of water produced. A high level of TOTAL DISSOLVED SOLIDS can be overcome with additional water pressure.
- 4.Membrane**-Different membranes have different characteristics. Some produce more water than others; some have better contaminant rejection capabilities; some have greater resistance to chemical abrasion for longer life. Pure-Pro system includes RE1812-70 The Thin Film Composite (TFC) membranes combine the best of these characteristics and are considered the finest membrane in the world.



Q: Can the Pure-Pro system be connected to an extra faucet?

It only takes a 1/4" tee and tubing to run the water to a refrigerator or a extra faucet. Some families run Pure-Pro system to all of their bathrooms.

Q: What does the Pure-Pro series drinking water taste like?

The taste of the Pure-Pro water depends on the amount of contaminants in the tap water originally. If 95% of dissolved minerals and chemicals are removed, the R.O. water may taste like distilled water (no minerals), bottled water (low mineral), or natural spring water (moderate mineral content).

Cartridge Filters

Cartridge Filters	Filter Description	Service Life
<p>Stage 1</p> <p>5 Micron Sediment Filter</p> 	With only five micron rating. It is effective in removing dirt, rust and sand particles.	6 Months
<p>Stage 2</p> <p>Granular Activated Carbon Filter</p> 	It takes out 99% of the chlorine and organic chemicals. It provides enhanced reduction of taste, odor, and color.	6 Months
<p>Stage 3</p> <p>Ultraviolet Water Sterilizer</p> 	Ultraviolet light (UV), a natural part of the sunlight is widely accepted as a reliable, efficient & environmentally friendly solution for water disinfection. This UV lamp utilize the application of particularly efficient UV radiator with a 254nm wave length to cause immediate death for organisms and wipe out their ability to survive and reproduce. 99.99% destruction of bacteria and viruses.	1 Year

The parts of UV-301

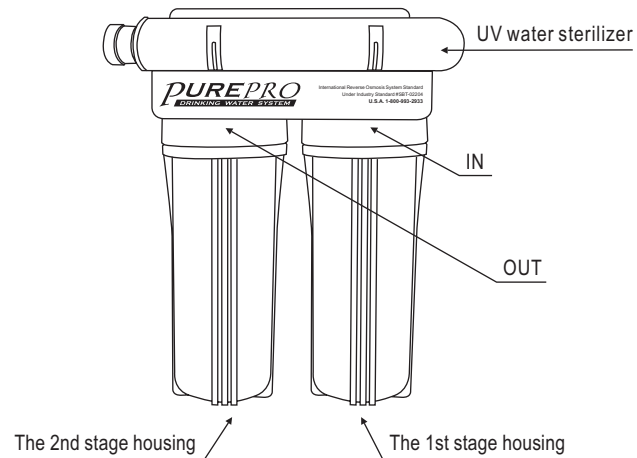

UV-301 3 Stage Ultraviolet (UV) Water Purification System

Operation regulation

- With everything connected, turn on the water check for leaks.
- Let the water run for at least 30 minutes. This flushes the carbon filters on first time use.
- Change filters regularly every 6 to 12 months and have the membrane checked annually.

Caution

- Do not use hot water (over 45°C)!
- Do not freeze the machine!
- Switch off electricity and water source if away for more than 5 days, and drain out pure water.

UV-301 3 Stage Ultraviolet (UV) Water Purification System

Operation regulation

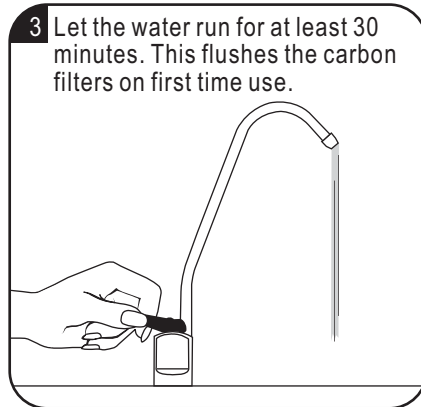
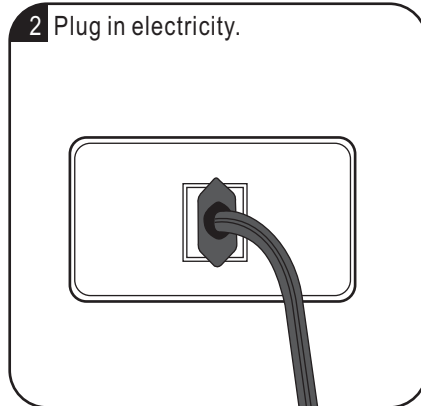
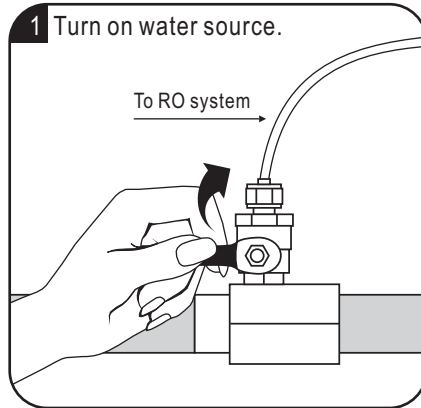

UV-301 3 Stage Ultraviolet (UV) Water Purification System

PUREPRO
DRINKING WATER SYSTEM

Tubing connection diagram

CONNECTING THE COLOR TUBING:

- A. Connect the WHITE tubing to the water supply connector.
- B. Connect the BLUE tubing to the sink top faucet.

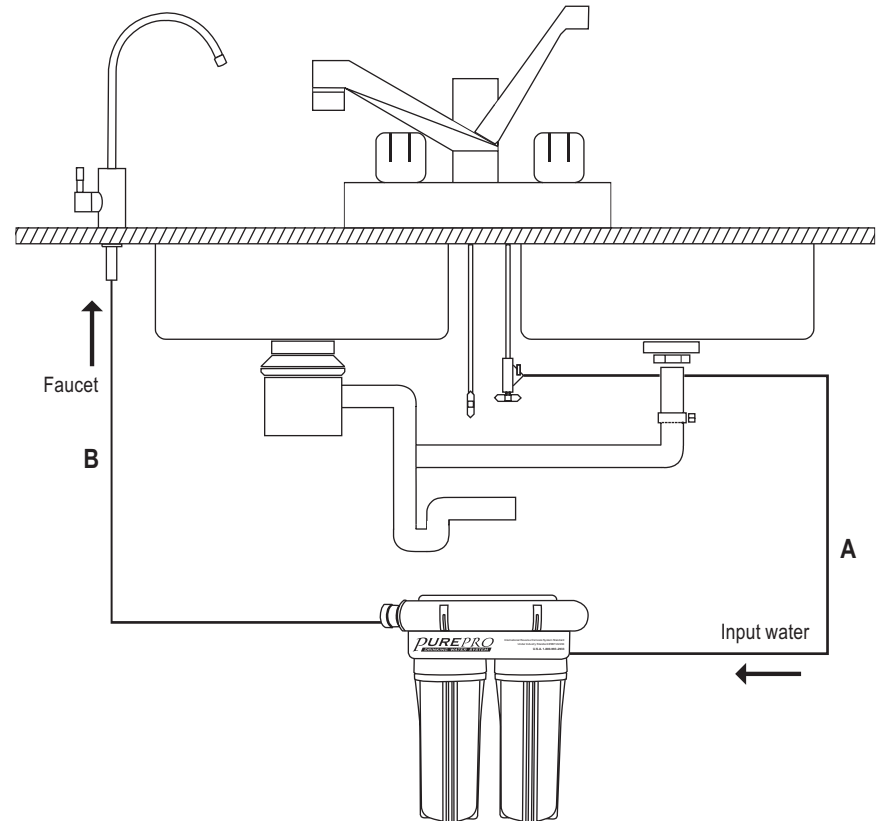

UV-301 3 Stage Ultraviolet (UV) Water Purification System

PUREPRO
DRINKING WATER SYSTEM

Installation diagram

Input water :

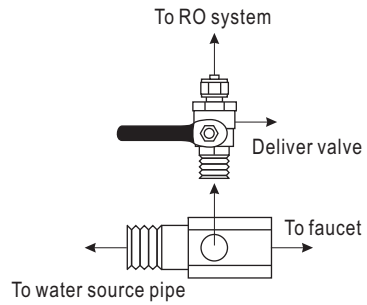

Install European ceramic faucet :

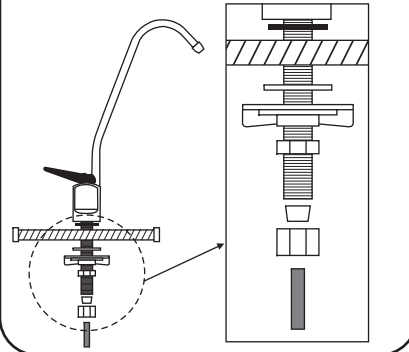

Install UV lamp :

1. Take out the UV sterilizer from the box as shown in the picture.

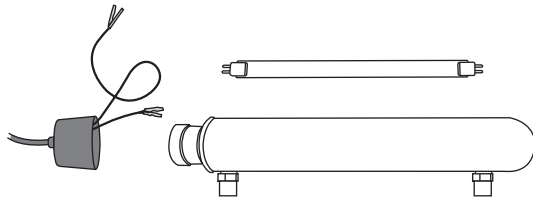

2. Connect the wire to both ends of UV lamp.

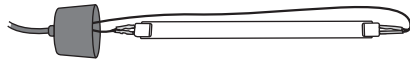

3. Tight up the UV cap.



Change filters

1 Prepare a housing wrench.

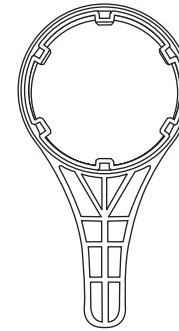

2 Unplug electricity.

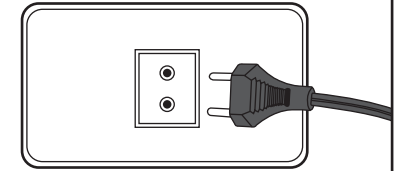

3 Turn off water source.

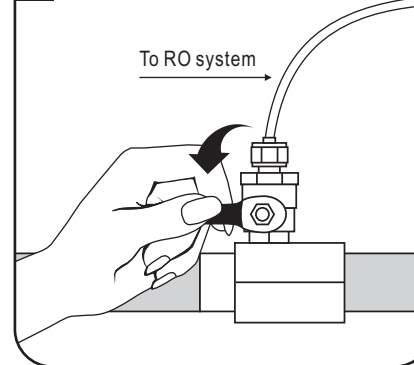

4 Open housings clockwise with a wrench.

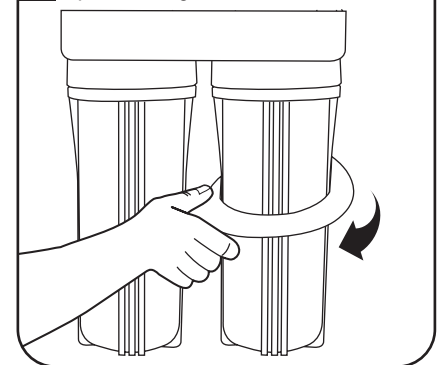

5 Put the replacement filters in the housings and double O' ring.

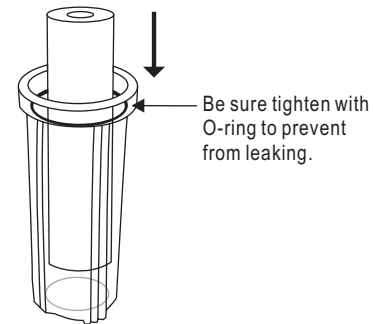

6 Drain out 1 Gallon of water to purify replacement filters.

